

TWINSKAN 3", GAS AND DIESEL TACH (New LCD)

This manual (part # 1000-158-01) applies to the following product part numbers:

- 1) 3TB013
- 2) 3TB013U
- 3) 3TB014
- 4) 3TB014M
- 5) 3TB014U
- 6) 3TB016
- 7) 3TB016M
- 8) 3TB016U
- 9) 3TB016U-WC
- 10) 3TB018
- 11) 3TB018U
- 12) 3TB023
- 13) 3TB023M
- 14) 3TB024
- 15) 3TB026U
- 16) 3TB028
- 17) 3TB028U
- 18) 3TS013
- 19) 3TS013M
- 20) 3TS013U
- 21) 3TS014
- 22) 3TS014U
- 23) 3TS016
- 24) 3TS016U
- 25) 3TS023
- 26) 3TS023U
- 27) 3TS024
- 28) 3TS024M
- 29) 3TS024U
- 30) 3TS026
- 31) 3TS026U
- 32) 3TS026U-WC
- 33) 3TS028
- 34) 3TS028U
- 35) 3TW023
- 36) 3TW023U
- 37) 3TW024
- 38) 3TW024M
- 39) 3TW024U
- 40) 3TW026
- 41) 3TW026M

- 42) 3TW026U
- 43) 3TW028
- 44) 3TW028U

TwinScan 3" Tachometer (LCD)

To ensure years of trouble free operation of your new TwinScan instrument, please read all of these instructions carefully before beginning your installation.

1. Mounting Location

TwinScan instruments allow you to quickly monitor and compare port and starboard engine performance. The front faces of all TwinScan® instruments are water-resistant and include a gasket to seal the instrument to the panel. Please note that TwinScan instruments contain magnets that may affect your compass. Use care in choosing a mounting location.

2. Start-up Sequence and Normal Operation

The TwinScan tachometer performs a quick self-test each time it is powered up. The self-test verifies adequate power, good ground connections, that the pointers are free, and the LCD display is working properly. During this test, the pointers will sweep smoothly from zero to full scale and then back to zero. The LCD shows a series of numbers as detailed below (*example values are used, so actual numbers may differ*). Switches and configurations are shown on the LCD as: "0123456789AbCdEF"

"8 . 8 . 8 . 8"	Checks LCD segments and backlighting.
" 1 . 2 0"	Software version number.
"F 3"	The red (left) and black (right) knob settings (on back of instrument).
"- - 3 4"	Internal configuration (scale range, units, etc.)
" "	Blank
" 4 . 0"	Cycles per revolution as set by the red and black knobs (refer to calibration sheet—Table 1).
" "	Blank

After the self-test, the instrument goes into its normal operating mode. The needles indicate engine rpm and the LCD displays a synch indicator or nautical miles per gallon/liters per nautical mile depending on the "synch / MPG" ("synch / L/NM") select switch.

3. LCD Synchronizer Indicator

In engine-synch mode, the LCD is programmed to display a bar-graph indicator. A series of vertical bars will appear on the side of the faster running engine. The number of bars displayed depends on how far the engines are out of synch and the synch resolution setting on the back of the instrument (see calibration sheet for details). When the engines are synchronized an "IN SYNCH BAR" appears in the center of the display. When one of the engines is not running, two small rectangles will appear in the corner of the LCD display. For example, if the starboard engine is at idle and the port engine is not running the two small rectangles will appear in the bottom left side of the display. Please refer to the diagram below for examples of synch displays.

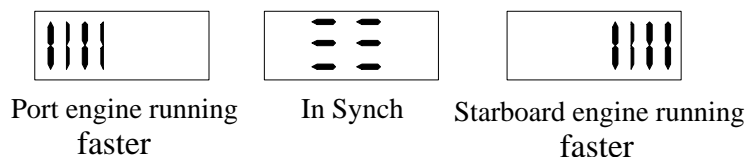

FIG. 1 SYNCH DISPLAY

The number of bars visible in the display indicates how far the engines are out of synch. Referring to the gas engine settings in the chart below, the display shows one vertical line if the engines are within 200 rpm (coarse) or 100 rpm (fine); it will only indicate “IN SYNCH” if the engines are within 100 and 50 for the coarse and fine resolution respectively.

Number of bars displayed	Coarse (gas)	Fine (gas)	Coarse (diesel)	Fine (diesel)
≡ ≡	100	50	50	20
	200	100	100	50
	300	250	200	150
	400	400	300	300
	over 400	Over 400	over 300	over 300

Table 1 Synch resolution

4. Nautical Miles per Gallon/Liters per Nautical Mile

The TwinScan tachometer displays nautical miles per gallon or liters per nautical mile (depending on the internal configuration of the instrument) when it is used in conjunction with the TwinScan GPH and a device that outputs a NMEA 0183 data stream (GPS, Loran C, etc.).

During normal vessel operation, adjusting engine RPM to your maximum MPG (L/NM) reading maximizes your fuel mileage. When switching from the synch mode to MPG (L/NM), you will notice the display temporarily indicate MPG—“nPG” or L/NM—“LPn” before it starts reading efficiency. The speed and flow data are smoothed for about 30 seconds, so wait for 30-60 seconds after making a throttle or trim change for the MPG/LPM reading to respond. Vessel trim, load, adjustment of trim tabs, water currents and weather conditions also affect your fuel consumption. For similar operating conditions, dramatic changes in MPG (L/NM) readings indicate possible mechanical malfunction, propeller damage or excessive bottom fouling and should be investigated.

Your current MPG (L/NM) reading on the TwinScan Tachometer instrument and GALLONS (LITERS) reading on the TwinScan GPH (LPH) instrument allow you to quickly and easily estimate your current maximum cruising radius. For safety, allow a margin of error when calculating your next fuel stop.

5. Illumination

TwinScan instruments use a dual method of illumination to create a high contrast display making it easy to read at night without affecting your night vision. The pointers are individually lighted so all the port pointers light when the port key switch is energized and all the starboard pointers light when the starboard key switch is energized. “Light piping” directs the light from an incandescent lamp across the dial face instead of bouncing it off the dial face and into your eyes.

6. Caring for your instrument

The front lens of your TwinScan instrument is made of hardened Lexan and is resistant to mild abrasion. Use mild soap and water to clean. Never wipe with a dry cloth. This can scratch the lens and builds up static electricity attracting dust and dirt. Avoid solvents such as acetone, benzene, and lacquer thinner as they attack the surface of the lens. Most window and kitchen cleaners contain at least one of these solvents plus mild abrasives and should be avoided. Applying automobile or furniture wax covers minor scratches on the lens and helps prevent further scratching.

TwinScan 3” Instrument – Tachometer & GPH Gas – NMEA 0183 Input (LCD)

COMBINATION ONLY

This unit conforms to NMEA 183, Version 1.5 and 2.0 interface standards, and requires a message that includes “VTG”, “RMC” or “RMA”. Check your owner’s manual to verify your GPS / LORAN-C includes this information. To insure an easy trouble free installation, read all instructions before starting.

WIRING

1. Refer to the electrical wiring section of the GPS / LORAN-C Owner’s Manual for the proper procedure to connect your GPS / LORAN-C to NMEA 183 devices. Use shielded wire between instruments and ground the shield ONLY at the GPS / LORAN-C (sender end), not at the FloScan instrument end (receiver end). The shield is not to be used as a ground path.
2. Connect the WHITE/ORANGE wire to the NMEA (+) (BNC center terminal) terminal coming from your GPS / LORAN-C instrument.
3. Connect the GREEN/BLACK wire to the NMEA (-) (BNC shield) terminal coming from your GPS / LORAN-C instrument.
4. Connect the BLUE wire to the WHITE/RED wire from the TwinScan GPH meter and to one terminal of a single pole, single throw switch. Connect the other terminal to the BLACK wire (system ground).

CALIBRATION

1. See your GPS / LORAN-C owner’s manual and set output for NMEA 0183 version 1.5 or 2.0 at 4800 bits/sec. (standard). Speed is always sent on the NMEA string as speed over ground in knots no matter what units your GPS / LORAN-C displays.
2. Fuel flow rate calibration is automatically done when the totalizer is calibrated. To calibrate, see the Totalizer calibration instruction page.

FUEL ECONOMY/SYNCH OPERATION

The blue wire must be connected to an operating TwinScan fuel flow meter to show fuel economy, otherwise the instrument shows the synchronizer regardless of this switch position.

1. With the MPG/SYNCH switch in the ON position (BLUE wire closed, grounded), your instrument displays the engine synchronizer. In the OFF (open) position, the instrument shows fuel economy in nautical miles per gallon or liters per nautical mile and is automatically selected by the TwinScan GPH/LPH instrument. You must have valid NMEA 0183 version 1.5 or 2.0 speed data to display fuel economy; otherwise you receive an error code:

ERROR CODES

Display	Reason	Cause
“ OFF ”	No signal activity present on NMEA 0183 terminals for four seconds.	GPS / LORAN-C OFF NMEA OUTPUT not selected Leads not connected (+) & (-) leads reversed
“- . . . -”	Receiving NMEA 0183 Version 1.5 or 2.0 message, but speed message is invalid.	GPS satellite reception is poor GPS / LORAN-C in startup mode
“- Lo -”	(MPG mode) Speed valid but flow rate less than 0.25 GPH.	Flow rate too low—engine stopped
“- hi -”	(LPM mode) Speed valid but less than 0.2 KM.	Speed too low—boat stopped
“Err1”	Some pulsing signal present but no NMEA 0183 message received in last four seconds.	Leads connected to wrong source GPS / LORAN-C set to NMEA 0180 or 0182 (+) & (-) leads reversed.
“Err2”	NMEA 0183 message detected, but no “VTG”, “RMC” or “RMA” sentence found.	GPS / LORAN-C incompatible with NMEA 0183, version 1.5 or newer

Note: THIS SHEET IS TO BE USED ONLY WHEN INSTALLING A TWINSCAN GPH METER AND TACHOMETER COMBINED.

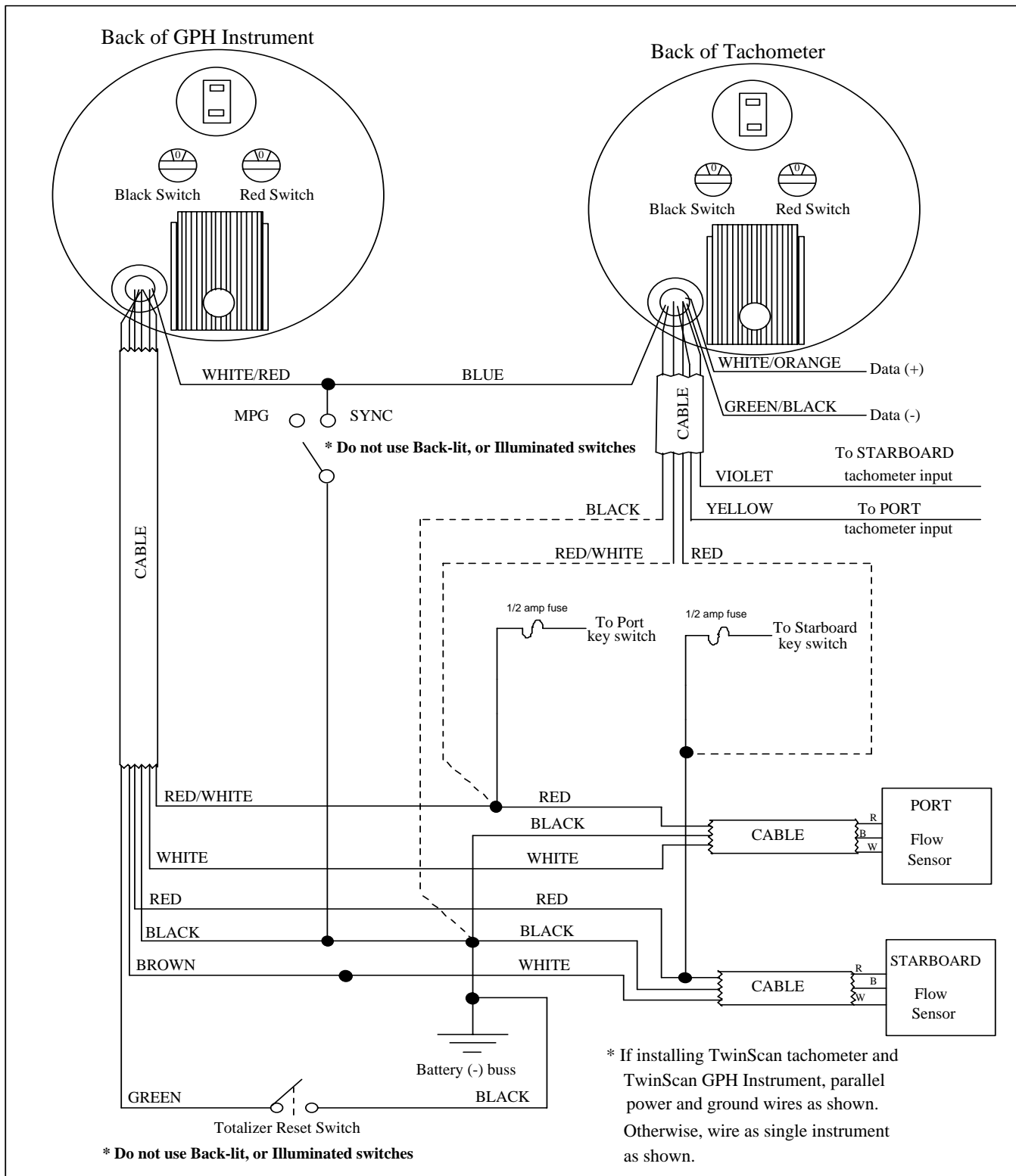

Series 5400(0)/5500(0)/56100/5800(0)/6500(0)/6600(0) AccuTroll & CruiseMaster, All Multi Function Instruments, & TwinScan®

SET UP

Wire & Switches: Use 18 AWG stranded wire on runs under 50'. For runs over 50' use 16 AWG. Shielded wire is recommended for all Diesel systems and suggested for Inboard & I/O gasoline systems. Always, "Ground" the wire shield or shield drain wires in the engine room by connecting them to the bonding system or engine block. The double wiring harness for twin engine Pulse/NMEA Diesel installations is included in all, (97/9800(0)) kits. FloScan suggests using J-Boxes, Terminal Blocks, and three conductor cables between diesel sensors and instrument to make wiring easier.

Install Single Pole Single Throw (SPST) switches for Totalizer Reset, Port-Starboard Select, Engine Hours / Synchronizer, and GPH / MPG, (switches are not included with kit). To determine which switch types are required for your system, refer to the table below. All instruments except TwinScan Tachometers require a totalizer reset switch.

SYSTEM	TOTALIZER RESET	PORT/STBD Twin Engine Systems	HOURS/ SYNCH	GPH/ MPG	MPG/ SYNCH
5400(0)	SPST or Momentary <u>OFF</u>	SPST	NA	NA	NA
5500(0)/56100	SPST or Momentary <u>OFF</u>	SPST	NA	NA	NA
5800(0)	SPST or Momentary <u>OFF</u>	NA	NA	NA	NA
6500(0)/6600(0)	SPST or Momentary <u>OFF</u>	NA	NA	NA	NA
65/6600(0) Cummins PT	SPST or Momentary <u>OFF</u>	SPST	NA	NA	NA
7000/8000(0) Gasoline MFI	SPST or Momentary ON	SPST	SPST	NA	NA
71/8A00(0) MFI - Gasoline EFI	SPST or Momentary ON	NA	NA	NA	NA
75/7600(0) Diesel MFI	SPST or Momentary ON	NA	NA	NA	NA
9000 Gasoline MFI	SPST or Momentary ON	SPST	SPST	SPST	NA
9A00(0) MFI - Gasoline EFI	SPST or Momentary ON	NA	NA	SPST	NA
95/96/97/9800(0)	SPST or Momentary ON	NA	NA	SPST	NA
TwinScan GPH Meter	SPST or Momentary ON	NA	NA	NA	NA
TwinScan Tachometer	NA	NA	NA	NA	NA
TwinScan GPH & Tachometer	SPST or Momentary ON	NA	NA	NA	SPST

NA = Not Applicable

Grounding: Each Black sensor wire must be connected directly to the Black, "Instrument Ground" wire. Use a single wire to connect the Black wire junction to the battery's negative terminal, or a ground buss.

Power: FloScan Instruments & sensors operate on 9 to 12 VDC. Voltages exceeding 16 VDC will damage equipment. 24 & 32 VDC systems must be reduced to 12 VDC. Two different types of voltage reducers are available through FloScan.

WIRE CONNECTIONS

Installation: Connect wires one at a time and install heat shrink tubing before proceeding to the next wire, (refer to diagram). Connect ground wires first, (BLACK instrument ground wire to the BLACK sensor wires). Connect this junction to the battery's negative terminal or the ground buss. Connect all other wires leaving the Red power wires for last to prevent short circuits during installation.

Splicing: Splice or join individual wires per the diagram. Slide heat shrink tubing over the splices to prevent shorts. Do not seal splices until the installation is finished and has been tested.

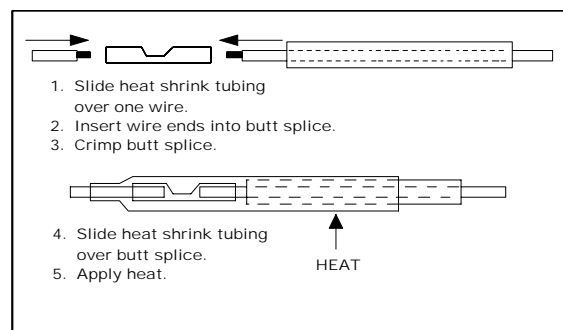

An adequate number of crimp-on connectors and heat-shrink tubing are included with system. The heat-shrink is a special type that will bond to wire insulation and make a watertight connection. See diagram for proper tubing application. Crimp-on connectors are sized for 18 or 20 gauge stranded wire.

Tachometer Wiring Information applies only to MFI & TwinScan Instrument Tachometers

Tachometer signal wires on MFI & TwinScan Tachometers should be shielded.

For proper tachometer operation on gasoline EFI engines, (especially outboards) the engine Ground wire must be physically connected to the MFI or TwinScan instrument ground wire.

Note: FloScan recommends using dedicated 18 AWG shielded cable for tachometer signal wire connections. Always, “Ground” wire shields or the shield drain wire in the engine room by connecting to the bonding system or engine block.

MULTI FUNCTION & TWINSCAN INSTRUMENT TACHOMETERS for CARBURETOR & CLOSED LOOP EFI GASOLINE ENGINES POINTS or STANDARD ELECTRONIC IGNITIONS

Inboard, & I/O Engines: Connect the YELLOW wire from pin # 8 to the distributor coil’s negative terminal. On twin engine systems the Yellow wire from pin # 8 connects to the port engine, the VIOLET wire from pin # 16 to starboard.

Outboard Engines: Outboard tachometers are connected to either the engine alternator or tachometer signal wire. Connect the YELLOW wire from pin # 8 to the engine alternator or tachometer signal wire. On twin engine systems the Yellow wire from pin # 8 connects to the port engine, the VIOLET wire from pin # 16 to starboard.

MULTI FUNCTION & TWINSCAN INSTRUMENT TACHOMETERS for CLOSED LOOP EFI GASOLINE ENGINES with CPU IGNITION SYSTEMS

Inboard, I/O, & Outboard Engines: Connect the YELLOW wire from pin # 8 to the engines’ tachometer signal wire. On twin engine systems the Yellow wire from pin # 8 connects to the port engine, the VIOLET wire from pin # 16 to starboard.

Outboard Engines: Connect the YELLOW wire from pin # 8 to the engines’ tachometer signal wire. On twin engine systems the Yellow wire from pin # 8 connects to the port engine, the VIOLET wire from pin # 16 to starboard.

MULTI FUNCTION INSTRUMENT TACHOMETERS for OPEN RETURN EFI GASOLINE ENGINES with CPU IGNITION SYSTEMS

Inboard & I/O Engines: Connect the YELLOW wire, pin # 8 to the engines’ tachometer signal wire.

MULTI FUNCTION INSTRUMENT TACHOMETERS - DIESEL ENGINES

- Keep existing tachometer: Connect the YELLOW and VIOLET wires to the existing tachometer signal wires. If one lead is grounded at the pickup or alternator, connect the YELLOW wire to the tachometer signal wire. Connect the VIOLET wire to a ground buss.
- Replace existing tachometer: Connect the YELLOW and VIOLET wires to the existing magnetic pickup or signal generator. If one lead is grounded at the pickup or alternator, connect the YELLOW wire to the existing signal wire terminal at the tachometer and connect the VIOLET wire to a ground buss.
- Install as a new tachometer. On engine alternator installations, connect the YELLOW wire to the tachometer output terminal (usually marked “tach” or “sig”) and connect the VIOLET wire to a ground buss. For mechanically driven A-C signal generators and magnetic pickups, connect the YELLOW wire to one terminal and the VIOLET wire to the other.

TWINSCAN INSTRUMENT TACHOMETERS – DIESEL ENGINES

- Connect the YELLOW wire to one terminal the Port tachometer sender, (AC signal generator, Magnetic pickup, or the engines’ alternators tach or sig terminal). Connect the VIOLET wire to the Starboard sender. The tachometer senders’ second terminal must be grounded.

FINAL ACTIONS

Check Electrical Installation: Test all connections. Support and secure all dangling wires. Start engine and calibrate system.

TwinScan Gas & Diesel Tachometer

Tachometer Wiring: For proper tachometer operation on Gasoline EFI engines, (especially outboards) the engine Ground wire must be directly connected to the TwinScan Tachometer ground wire. FloScan recommends using dedicated 18 AWG shielded cable for tachometer signal wire connections. Always, "Ground" wire shield or shield drain wire in the engine room by connecting it to the bonding system, or engine block.

CARBURETOR & CLOSED LOOP EFI GASOLINE ENGINES with POINTS or STANDARD ELECTRONIC IGNITIONS Inboard, & I/O Engines: Connect the Yellow tachometer signal wire to the negative terminal of the port engines' distributor coil. Connect the Violet tachometer signal wire to the negative terminal of the starboard engines' distributor coil.

Outboard Engines: Outboard motor tachometers are connected to either the engine alternator or tachometer signal output wire. Connect the Yellow tachometer signal wire the port engines' alternator or tachometer signal output wire. Connect the Violet tachometer signal wire to the starboard engines' alternator or tachometer signal output wire.

CLOSED LOOP EFI GASOLINE ENGINES with CPU IGNITION SYSTEMS

Inboard, I/O, & Outboard Engines: Connect the Yellow tachometer signal wire to the port engines' tachometer signal output wire. Connect the Violet tachometer signal wire to the starboard engines' tachometer signal output wire.

CHRYSLER (Except Magnapower I) - Connect tachometer signal wire(s) to the engine terminal strip marked, "ALT".

JOHNSON/EVINRUDE/SEADRIVE - Connect tachometer signal wire(s) to the gray wire at key switch harness or Gray/Yellow alternator wire on engine terminal strip. For 1984 and later model years with standard voltage regulators, connect the tachometer signal wire(s) to either the Gray voltage regulator wire, or the Yellow/Gray alternator wire on the engine terminal strip.

MERCURY/MARINER - Attach tachometer signal wire(s) to the Yellow/Red, or Yellow wire terminal on engine rectifier.

SUZUKI - Remove three screws from rear of the throttle control box and remove cover plate. Attach tachometer signal wire(s) to the Yellow wire, and shield ground wire to Black wire. Keep wires away from the moving parts in control box and reinstall back cover.

YAMAHA - Attach tachometer signal wire(s) to the Green wire, and shield ground wire to the Black wire at underside of shift control box. If the Green wire is not accessible at control box, either Green wire on engine terminal strip can be used.

DIESEL ENGINES

New Installations: TwinScan Diesel Tachometers can use an Engine Alternator, Mechanically Driven AC Signal Generator, or a Magnetic Pick-Up as the tachometer signal source.

- **Engine Alternator:** Connect the Yellow tachometer signal wire to the port alternators' tachometer output terminal (usually marked "Tach" or "Sig"). Connect the Violet tachometer signal wire to the starboard alternators' tachometer output terminal.
- **Mechanically Driven A-C Signal Generator, Magnetic Pickup:** Signal Generators and Magnetic Pick-Ups have two terminals. One terminal must be connected to battery minus or a ground buss. Connect the Yellow tachometer signal wire to the open terminal on the port signal generator or magnetic pickup. Connect the VIOLET tachometer signal wire to the open terminal on the starboard signal generator or magnetic pickup.

Keep or Replace Existing Tachometer: Connect the Yellow tachometer signal wire to the port tachometers signal output wire. Connect the Violet tachometer signal wire to the starboard tachometers signal output wire. If using an AC Signal Generator or Magnetic Pick-Up as the tachometer signal source, verify that one terminal is grounded.

FINAL ACTIONS

Check Electrical Installation: Test all connections. Support and secure all dangling wires to prevent accidental breakage. Proceed to operate system and calibrate.

**Installation Instructions
TwinScan® 3” Instrument – Tachometer Only
Gas and Diesel Engines**

To ensure years of trouble free operation of your new TwinScan® Instrument please read all of these instructions carefully before beginning your installation.

CAUTION: To avoid electrical shorts and possible fire, turn **OFF** the power to the instrument panel until installation is complete.

WIRING

Use No. 18 AWG multi-strand wire, the included butt splices, and self-sealing heat shrink to make all connections. **Alternate installation:** Use insulated ring tongue connectors and a terminal strip. **DO NOT** solder connections. Vibration can cause wire to break where solder stops and cause intermittent connections.

Installation: Make a 3 3/8” diameter cutout in the instrument panel for the instrument.

Important: Protect wires from damage caused by sharp edges, moving and hot engine parts. Cable tie and support all wire runs for safety.

MAIN WIRING

Wire Color	Function
RED/WHITE	PORT + 12 VDC Power
RED	STARBOARD + 12 VDC Power
BLACK	Battery Ground
YELLOW	PORT tachometer input
VIOLET	STARBOARD tachometer input
BLUE	Flow Input
WHITE/ORANGE	GPS Input, NEMA + (A)
GREEN/BLACK	GPS Input, NEMA - (B)

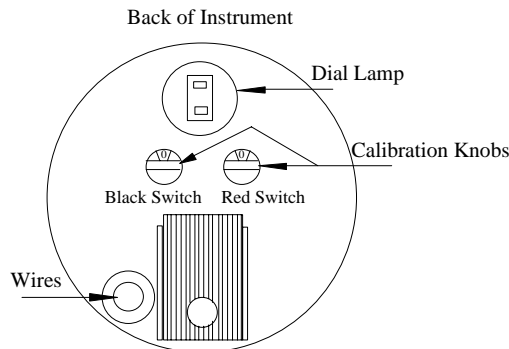

1. Connect the RED/WHITE stripe wire to the “power on” side of the PORT engine key switch.
2. Connect the RED wire to the “power on” side of the STARBOARD engine key switch.
3. Connect the BLACK wire to the negative (-) side of the battery buss.
4. Connect the YELLOW wire to the PORT engine tachometer pickup.
5. Connect the VIOLET wire to the STARBOARD engine tachometer pickup.

Note: If not installing a TwinScan GPH instrument, leave the following wires disconnected (tape them off).

6. Connect the BLUE wire to the WHITE/RED wire from the TwinScan GPH instrument.
7. Connect the WHITE/ORANGE wire to the GPS (+) terminal (A).
8. Connect the GREEN/BLACK wire to the GPS (-) terminal (B).

NOTE: The industry standard for tachometer pickup wire(s) color coding is as follows:
 PORT side = GREY/RED STARBOARD side = GREY/GREEN

This completes the Tachometer wiring. See TACHOMETER CALIBRATION sheet for calibration information.

WIRING SCHEMATIC FOR GAS AND DIESEL TWINSKAN TACHOMETER

10/21/1999

1000-109-00E

Wiring Schematic For Gas Twinscan Tachometer

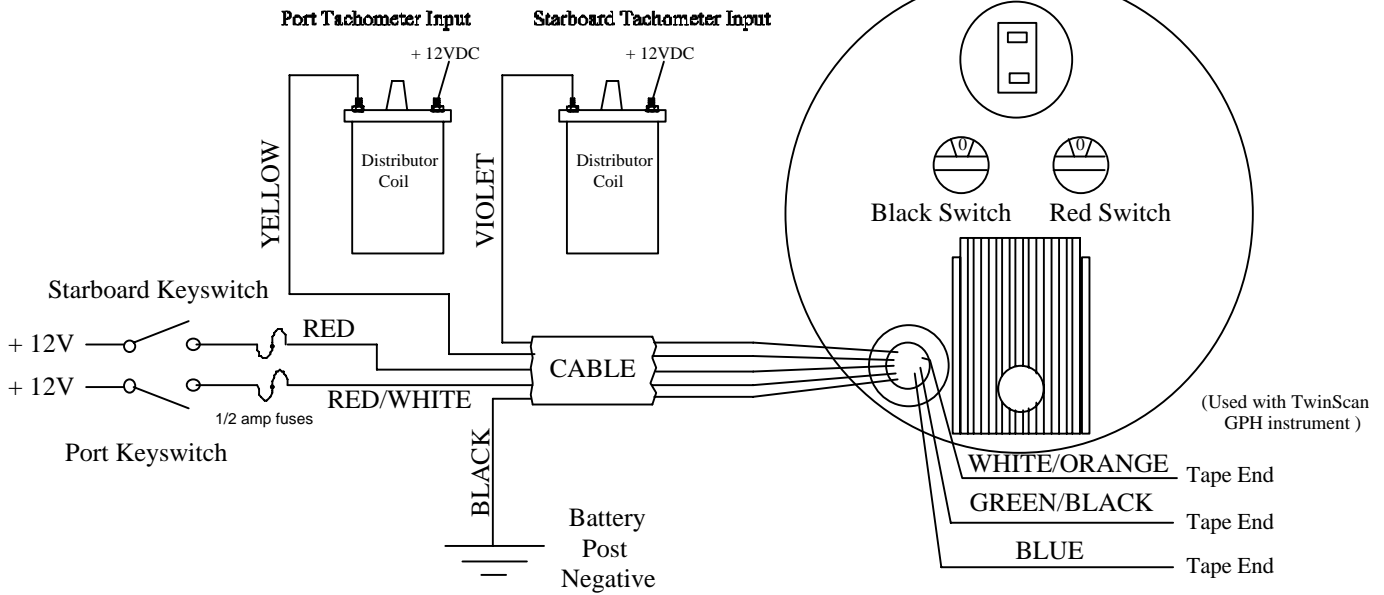

Wiring Schematic For Diesel Twinscan Tachometer

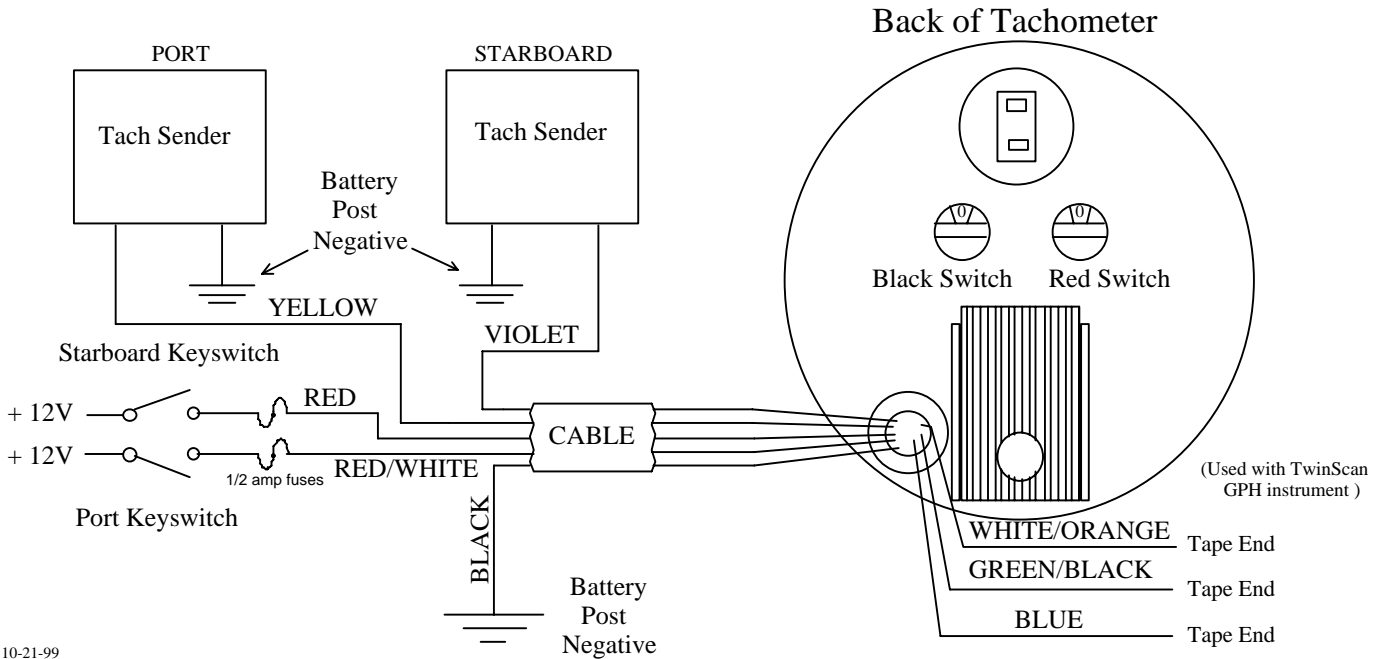

10-21-99

TwinScan 3” Instrument – Tachometer (LCD) Diesel Engines

The TwinScan 3” Tachometer is unique in that it can be calibrated for both gasoline and diesel systems. On the back of the TwinScan 3” Tachometer Instrument, the **RED** switch is used for fine calibration. The **BLACK** switch is used for coarse calibration. You will use a combination of both switches for proper calibration.

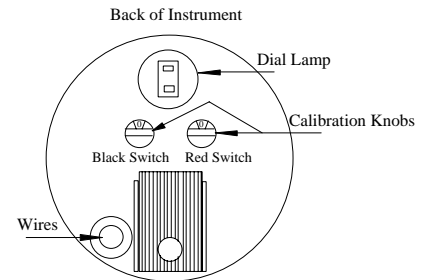

DIESEL SYSTEM CALIBRATION

Diesel systems have three options for tachometer pick-up styles, **Mechanical AC Generator**, **Magnetic Pick-up**, and **Alternator**. **Table 1** will be used to calibrate any style of tachometer pickup you may have. Please read the section pertaining to your specific tachometer pick-up style for instructions on calibrating the tachometer.

I. MECHANICAL AC GENERATOR

- Determine the number of pole pairs of your generator. Some examples are:

<i>Century Brass</i>	8	<i>Stewart Warner</i>	8
<i>Hewitt</i>	8	<i>Synchrostart</i>	30
<i>VDO</i>	4	<i>Motorola</i>	8

- Determine the ratio of the number of revolutions of the crankshaft drive to the number of revolutions of the tachometer. For most engines, the ratio is **0.5**. If you are not sure of your tachometer drive ratio, you can either check with your local engine dealer or you can adjust the **RED** and **BLACK** switches until you get a reading of 500-800 RPM at a normal idle with the engine at or near normal operating temperature.
- Calculate the proper switch setting:

Tachometer drive ratio x number of generator pole pairs = number used to determine **RED** and **BLACK** switch settings from **Table 1**.

Example: Installation - Caterpillar 3208 with an 8 pole pair generator.

Crankshaft revolution to tachometer drive = **0.5** ratio.

Generator = 8 pole pair.

0.5 (ratio) x 8 (pole pair) = 4 (*generator produces 4 pulses per revolution*).

The switch setting selection would be as follows:

50 RPM synchronized resolution	- RED switch = 3	BLACK switch = 1
20 RPM synchronized resolution	- RED switch = 3	BLACK switch = 9

II. MAGNETIC PICK-UP

This instrument **must** be calibrated at the time of installation to your specific engine in the following manner:

- Determine the number of pulses of the magnetic pick-up per crankshaft revolution. If you are not sure what this is, contact your local engine dealer and they can provide this information.

Pulses = (number of teeth on gear) x (number of revolutions of gear per crank shaft revolution).

The table steps allow setting to be within +/- 1% to 2% of the actual pulse count. As this applies to both engines, the synchronizing accuracy is not affected.

- Locate the number of pulses per crankshaft revolution in **Table 1**. Select the number closest to your actual pulses per crankshaft revolution.

Example: Pulses per crank shaft revolution = 160. From **Table 1**:

50 RPM synchronized resolution	- RED switch = B	BLACK switch = 6
20 RPM synchronized resolution	- RED switch = B	BLACK switch = E

III. ALTERNATOR

6/16/2006

1000-207-00

The alternator input usually comes off one of the windings of the alternator before it is rectified. This tachometer signal is inconsistently inaccurate because of a varying amount of belt slippage depending on the load on the alternator, the dimension of the belt and the belt tension.

Calibration

You can calibrate the tachometer by two methods:

1. Calibrate to the existing tachometer. Simply rotate the *RED* and *BLACK* knobs on the back of the instrument until the two tachometers agree with each other. The accuracy of this method depends on the accuracy of the existing tachometer at the RPM to which you calibrate. It is best to compare to the existing tachometer at cruising RPM or higher, not at idle.
2. You need the number of poles the alternator has to determine the number of pulses per revolution. Multiply this times the ratio of the diameter of the crankshaft pulley. Divide this number by the diameter of the alternator pulley.
3. Locate the number of pulses per crankshaft revolution in **Table 1**. Select the number closest to your actual pulses per crankshaft revolution.

Example: Motorola alternator has 12 pole pairs (*12 pulses per revolution*)

Crank shaft pulley = 10" diameter Alternator pulley = 4" diameter

$12 \times (10 \div 4) =$ number of pulses per revolution $12 \times 2.5 = 30$ pulses per revolution.

From **Table 1** - **50 RPM synchronized resolution** - *RED* switch = **8** *BLACK* switch = **3**

20 RPM synchronized resolution - *RED* switch = **8** *BLACK* switch = **B**

Adjust the RED and BLACK switches for the pulses per revolution according to Table 1:

Table 1 Tachometer Calibration

Synchronized Resolution		BLACK Switch Setting						
		<i>9</i>	<i>A</i>	<i>B</i>	<i>C</i>	<i>D</i>	<i>E</i>	<i>F</i>
20 RPM		<i>9</i>	<i>A</i>	<i>B</i>	<i>C</i>	<i>D</i>	<i>E</i>	<i>F</i>
0 RPM		<i>1</i>	<i>2</i>	<i>3</i>	<i>4</i>	<i>5</i>	<i>6</i>	<i>7</i>
<i>RED</i> Switch Setting	<i>0</i>	1	13.9	23.8	39.5	63.5	111	190
	<i>1</i>	2	14.3	24.5	41	66	114	196
	<i>2</i>	3	14.6	25.3	42.5	69	117	202
	<i>3</i>	4	15	26	44	72	120	208
	<i>4</i>	5	15.4	26.8	45.5	75	123	214
	<i>5</i>	6	15.8	27.5	47	78	126	220
	<i>6</i>	7	16.3	28.3	48.5	81	130	226
	<i>7</i>	8	17	29	50	84	136	232
	<i>8</i>	9	17.8	29.8	51.5	87	142	238
	<i>9</i>	10	18.5	30.5	53	90	148	244
	<i>A</i>	11	19.3	31.3	54.5	93	154	250
	<i>B</i>	12	20	32	56	96	160	256
	<i>C</i>	12.4	20.8	33.5	57.5	99	166	268
<i>D</i>	12.8	21.5	35	59	102	172	280	
<i>E</i>	13.1	22.3	36.5	60.5	105	178	292	
<i>F</i>	13.5	23	38	62	108	184	304	

TwinScan 3” Instrument – Tachometer (LCD) Gasoline Engines

TwinScan 3” Tachometers are unique in that they can be used on gasoline and diesel engines. For gasoline engine calibration refer to the appropriate engine section, **Inboard** or **Outboard**.

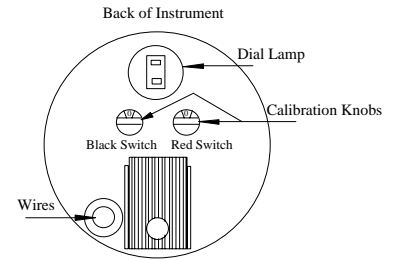

There are two calibration switches on the back of the instrument, Black and Red. Both are required for calibration. If there's an existing tachometer, or you know the engines' idle RPM, you can calibrate the tachometer without referring to Tables I, II, or III.

Decide on either Coarse or Fine Synch resolution. Coarse resolution shows that the engines are synched when they are running within 100 RPM, fine resolution shows synch within 50 RPM. Begin calibrating by putting the Black switch on 0 or 8, 0 is recommended. Starting at 0, rotate the Red switch one, "click" at a time until you dial in the correct idle RPM.

- If the correct RPM cannot be dialed in, refer to Table I, II, or III below.

Inboard Engines:

Tachometer calibration for standard point and electronic ignition inboard engines is usually based upon the number of engine cylinders. EFI engines sometimes use a CPU to generate its tachometer signal. For these engines calibration is not always based on engine cylinders.

Standard Point & Electronic Ignition Inboard Engines

Coarse Synch Display, (Recommended)

Cylinders	BLACK	RED
4	0	1
6	0	2
8	0	3

Fine Synch Display

Cylinders	BLACK	RED
4	8	1
6	8	2
8	8	3

EFI Inboard Engines

Coarse Synch Display, (Recommended)

Cylinders	BLACK	RED
4, 6, or 8	0	1
4	0	1
6	0	2
8	0	3

Fine Synch Display

Cylinders	BLACK	RED
4, 6, or 8	8	1
4	8	1
6	8	2
8	8	3

Table 1: 4-Cycle Gasoline Inboard Engines

Outboard Engines:

Tachometer calibration for standard point and electronic ignition outboard engines is usually based upon the number of alternator pole pairs. EFI outboards sometimes use a CPU to generate its tachometer signal. Calibration for EFI engines is not always based alternator pole pairs. Refer to your engine manual or check with a local dealer to determine the number of alternator pole pairs your engine has.

Standard Points, Electronic Ignition, & EFI Outboard Engines

Coarse Synch Display, (Recommended)

Pole Pairs	Black Switch	Red Switch
2	0	1
4	0	3
6	0	5
8	0	7
10	0	9
12	0	B
14	0	D
16	0	F

Fine Synch Display

Pole Pairs	Black Switch	Red Switch
2	8	1
4	8	3
6	8	5
8	8	7
10	8	9
12	8	B
14	8	D
16	8	F

EFI Outboard Engines

Coarse Synch Display, (Recommended)

Pole Pairs	Black Switch	Red Switch
CPU	0	1

Fine Synch Display

Pole Pairs	Black Switch	Red Switch
CPU	8	1

Table II, 2&4-Cycle Gasoline Inboard Engines

Red Switch

		0	1	2	3	4	5	6	7	8	9	A	B	C	D	E	F	
100 RPM	50 RPM	0	1	2	3	4	5	6	7	8	9	10	11	12	13	14	15	16
		1	2	3	4	5	6	7	8	9	10	11	12	12.4	12.8	13.1	13.5	
	A	13.9	14.3	14.6	15	15.4	15.8	16.3	17	17.8	18.5	19.3	20	20.8	21.5	22.3	23	
Black Switch	B	23.8	24.5	25.3	26	26.8	27.5	28.3	29	29.8	30.5	31.3	32	33.5	35	36.5	38	
	C	39.5	41	42.5	44	45.5	47	48.5	50	51.5	53	54.5	56	57.5	59	60.5	62	
	D	63.5	66	69	72	75	78	81	84	87	90	93	96	99	102	105	108	
	E	111	114	117	120	123	126	130	136	142	148	154	160	166	172	178	184	
	F	190	196	202	208	214	220	226	232	238	244	250	256	268	280	292	304	

Table III: Pulses/Engine Revolution

TwinScan® 3” Instrument - Tachometer (LCD)

BEFORE CALLING FOR ASSISTANCE, COMPLETE THESE TROUBLESHOOTING CHECKS AND RECORD YOUR FINDINGS. TECHNICAL SUPPORT REQUIRES THIS INFORMATION BEFORE A RETURN AUTHORIZATION WILL BE ISSUED. IT TAKES ABOUT 20 MINUTES AND IS VERY IMPORTANT IN ANALYZING SYSTEM PROBLEMS.

Before starting, record instrument model number and switch settings.

MODEL # _____ SERIAL # _____

RED SWITCH POSITION _____ BLACK SWITCH POSITION _____

Perform the Instrument Diagnostic Test First. Record your findings.

I. INSTRUMENT DIAGNOSTIC SELF-TEST

- Secure power to the Red, and Red/White wires, (Turn both key switches OFF).
- Turn power on, (Either to one or both switches). At start-up, the instrument automatically performs a, “Self-test”.
- Verify that the pointer’s back-lighting glows Red, and that the LCD back-light is glowing Green.
- Observe that the pointers smoothly sweep to near full scale, (Slightly above or below) then smoothly drop back to zero.

The LCD display shows the following numbers and letters in sequence. These are examples actual readings may vary. Switch settings and configurations are shown on the LCD as, “0123456789AbCdEF”.

- 8.8.8.8 LCD segment and back-lighting check.
- 1.21 Software version number.
- F 3 Red, (Port) and Black (Starboard) switch settings.
- - 34 Internal configuration (scale range, units, etc.)
- Blank
- ≡ ≡ Synch display, (Indicates normal operation).

NOTE: If Tachometer is powered from on switch, a lower case oo will appear in one corner of the LCD.

- Record the software version _____ and switch settings ____ _____. FloScan Technical Support will ask for these.

The self-test verifies adequate power, a good ground, that the pointers move, and the LCD display is working.

FAULT	PROBABLE CAUSE	SEE SECTION:
Blank LCD Display	Wiring	Section II
No back-lighting	Wiring/bulb failure	Section II
High, Low or No Tachometer Reading	Wiring	Installation sheet
	Calibration	Calibration sheet
Fluctuating Tachometer	Wiring/continuity	Sections II, III
	In synch w/engine	
Wire Harness Continuity Test		Section III

II. SUPPLY VOLTAGE and GROUND TEST

- Measure voltage between the Starboard RED power wire, and the BLACK Instrument ground wire.
- Measure voltage between the Port RED/WHITE power wire, and the BLACK Instrument ground wire. _____ VDC
This reading should be approximately 12 VDC, but not lower than 10 VDC.

- If 12 VDC is not present, measure between the RED, or RED/WHITE power wire and a known good ground in the instrument panel. If you measure 12 to 14 VDC there may be an instrument ground problem. _____VDC
- If 12 to 14 VDC is not present check wiring, switches, fuse, and the 12 VDC power source.

III. CONTINUITY TEST

- Continuity testing requires access to the back of the Instrument and an Ohmmeter. It verifies that wires are not broken, shorted to ground, another wire, or to power. Before starting, secure all power. You will be testing the VIOLET, and YELLOW wires.
- Disconnect the Yellow wire harness conductor from the Port Tachometer Sender & Instrument wire. Connect a jumper from the YELLOW wiring harness conductor to a known good ground. At the Instrument, connect an Ohmmeter lead to its' YELLOW wiring harness conductor. Connect the other Ohmmeter Lead to a known, good ground. The Ohmmeter should read approximately 0.1 to 3 Ω . _____ (Ohm Reading)
- Disconnect the VIOLET wire harness conductor from the Port Tachometer Sender & Instrument wire. Connect a jumper from the VIOLET wiring harness conductor to a known good ground. At the Instrument, connect an Ohmmeter lead to its' VIOLET wiring harness conductor. Connect the other Ohmmeter Lead to a known, good ground. The Ohmmeter should read approximately 0.1 to 3 Ω . _____ (Ohm Reading)

IV. TACHOMETER PROBLEMS

Note: Refer to the engine owners' manual, wiring diagram, installation, and calibration instructions for parts A, B, & C below.

A. NO READING.

- Check continuity of the YELLOW and VIOLET Tachometer signal wires, (Section III). Verify that the tachometer signal wires are connected at the correct signal output point.

B. HIGH OR LOW READINGS.

- Verify that Tachometer is calibrated correctly.

C. FLUCTUATING READINGS.

- Listen to your engine(s). If engine speed cycles up and down, (when idling or underway) the tachometer reading will follow. This does not indicate a problem with the Tachometer, but may indicate engine problems.
- Verify that wiring connections are tight, clean and dry. Check continuity while shaking the wires. Ohm readings should be near zero and remain steady.
- Verify that the tachometer signal wires are connected at the correct signal output point.

This concludes system testing. If problems with your system persist, contact FloScan Technical Support with testing results.

TWINSCAN 3", GAS GPH (New LCD) Inboard & IO to 1000 HP, All Outboards

This manual (part # 1000-158-00) applies to the following product part numbers:

- 1) 3FB010U
- 2) 3FB010U3
- 3) 3FB011M1
- 4) 3FB011M2
- 5) 3FB012U
- 6) 3FB012U1
- 7) 3FB012U2
- 8) 3FB013U
- 9) 3FB013U1
- 10) 3FB013U2
- 11) 3FB014M2
- 12) 3FB015U
- 13) 3FB015U1
- 14) 3FB016M1
- 15) 3FB016U
- 16) 3FB016U1
- 17) 3FB016U2
- 18) 3FB018M
- 19) 3FB018M1
- 20) 3FB018M2
- 21) 3FB022U
- 22) 3FB022U1
- 23) 3FB022U2
- 24) 3FB023U
- 25) 3FB023U1
- 26) 3FB028M
- 27) 3FS012U
- 28) 3FS012U1
- 29) 3FS012U2
- 30) 3FS013U
- 31) 3FS013U1
- 32) 3FS013U2
- 33) 3FS015U1
- 34) 3FS021M
- 35) 3FS021M1
- 36) 3FS022U
- 37) 3FS022U1
- 38) 3FS022U2
- 39) 3FS023U
- 40) 3FS023U2
- 41) 3FS023U1

- 42) 3FS024M2
- 43) 3FS025U
- 44) 3FS025U1
- 45) 3FS026
- 46) 3FS026U
- 47) 3FS026U1
- 48) 3FS026U2
- 49) 3FS028M
- 50) 3FS028M1
- 51) 3FS028M2
- 52) 3FW012U1
- 53) 3FW013U2
- 54) 3FW016U1
- 55) 3FW020U
- 56) 3FW020U3
- 57) 3FW021M
- 58) 3FW021M1
- 59) 3FW021M2
- 60) 3FW022U
- 61) 3FW022U1
- 62) 3FW022U2
- 63) 3FW023U
- 64) 3FW023U1
- 65) 3FW023U2
- 66) 3FW024M
- 67) 3FW024M2
- 68) 3FW025U
- 69) 3FW025U1
- 70) 3FW025U3
- 71) 3FW026U
- 72) 3FW026U1
- 73) 3FW026U2
- 74) 3FW028M1
- 75) 3FW028M2
- 76) 3FW028M4
- 77) 3FS018M2



INSTALLATION PLANNING



READ ME FIRST - Mechanical & Electrical Installation Planning Saves Time!

FloScan systems are not difficult to install. Installing one requires only basic electrical & mechanical skills. With forethought and planning, your system will be installed with few problems.

I. Installation Preparation:

Review the mechanical installation instructions, then survey your vessel. Determine where the Sensor(s), Pulsation Damper(s), (if used) Switches and Instruments are to be mounted. Place them at their approximate locations. Measure fuel line lengths between system components, (Primary Filter, Sensor(s), Damper(s), Engine, and Fuel Tank). Determine fitting sizes and type of fittings needed for each plumbing connection, (JIC, SAE, NPT, NPTF, or Hose Barb).

FloScan Gasoline, "Hi-Flo" system components have ½" Female NPT ports.
FloScan Gasoline, "Lo-Flo" system components have ¼" Female NPT ports.

Review the electrical installation instructions. Open and survey your vessels wire ways and run 3-conductor cables from each sensor to the instrument. Tachometers require 1 or 2 additional conductors. If there's an existing tachometer, its signal wires can be used.

II. Mechanical Installation:

Install or mount the Sensor(s), Pulsation Damper(s), (If required) Instruments and Switches, (Reset, MPG, Port/Starboard, Synch).

III. Plumbing:

Mount sensor(s) where they're to be installed. On installations using **Fabric Braid A-1 Fuel Hose** install the correct HB X MNPT fitting into each sensor. Always assemble fittings using a fuel proof pipe thread sealant. **Never use Teflon Tape**. Use a hose cutter or knife to cut the fuel hose. Next install the hose onto the barb fittings. Hose should not be twisted, have adequate slack, an ample radius at all bends and be supported at reasonable distances, approximately 2-4 feet. When clamping hose onto the barbs, use 2 narrow or 1 wide stainless hose clamp on each hose end.

Wire Braid A-1 Aeroquip Type Fuel Hose or Hydraulic Hose: Mount the sensor(s) or sensor assemblies where they're to be installed. Mark the hose where it is to be cut. Remove hose and bring it to a hydraulic shop. Have them cut the hose and install hose ends. Reinstall the hoses and install the correct fitting into each sensor or sensor assembly. Always assemble fittings using a fuel proof pipe thread sealant. **Never use Teflon Tape**. Hoses should not be twisted, have adequate slack, an ample radius at all bends and be adequately supported at reasonable distances, approximately 2-4 feet. AP-50 copper sealing washers, (Connie Seals) or Flaretite seals may be required to seal JIC & SAE fittings.

IV. Electrical Installation:

Run cables between Sensor(s) and Instrument(s). Cables must be adequately supported at reasonable distances, approximately 2-4 feet. Wire Terminations—Referring to the wiring diagram. Connect Sensor, Instrument and Switches to their respective wires with crimp type butt or ring connectors. Always cover connectors and wire ends with heat shrink tubing.

V. System Start-Up:

Prime the fuel system and check for leaks. Start and run your engines. Look for leaks and other installation problems. If system is not operating properly refer to the Troubleshooting Instructions and correct any deficiencies.

VI. Calibration:

When system is running properly, refer to the calibration instructions and calibrate your system.

USCG approved fuel hose with either fabric or wire reinforcing braid meet the following standards:

<u>Hose Marking</u>	<u>Permeation Rating</u>	<u>2½ Minute Fire Test</u>
USCG Type A-1	100g/m ² /24hrs.	Required
USCG Type A-2	300g/m ² /24hrs.	Required
USCG Type B-1	100g/m ² /24hrs.	Not Required
USCG Type B-2	300g/m ² /24hrs.	Not Required

Table I

Installation Do's & Don'ts

Do	Don't
Use a Fuel Proof Pipe Thread Sealant when assembling fittings into fuel system components, (Loctite PST, Leak-Lock, or equivalent).	<u>Never use Teflon Tape!</u>
Use thin wall, low pressure, full flow type NPT or NPTF hose barb fittings.	Don't use Push-Lok, or Barb-Tite fittings. Avoid using JIC or SAE swivel fittings. If used always install copper conical sealing washers, (Connie seals) or fitting seals on fittings.
Double clamp all hose barb fittings.	Avoid using 90° elbow fittings.
Install Sensor(s) at a low point in the fuel system, as far from the engine as practical. Fuel must travel, "Up-hill" slightly after leaving the sensor. Verify correct orientation and fuel flow direction.	If possible, avoid bolting or mounting sensor(s) directly onto the engine.
Connect all, "Ground" wires to a Ground Buss, or directly to the Battery's Negative Terminal. Connect or, "Ground" wire shields to the engine block.	Never connect Instrument or Sensor "Ground" wires to the hull, engine block, or other machinery.
On Instruments with a GPS interface, connect FloScan's Data (+) to the GPS signal output. Connect Data (-) to the GPS signal ground.	Do not connect FloScan's Data (-) to the GPS Data (-).
Always use non-illuminated switches for Totalizer Reset, Port/Starboard Select, Hours/Synch, and GPH/MPG.	Never use illuminated, or back-lit switches.

TwinScan® 3” GPH Instrument – Gallons Per Hour (LCD)

To ensure years of trouble free operation of your new TwinScan® instrument, please read all of these instructions carefully before beginning your installation.

1. Mounting Location

The TwinScan® GPH instrument allows you to quickly monitor and compare port and starboard engine performance. The front faces of all TwinScan® instruments are water-resistant and include a gasket to seal the instrument to the panel in which it is installed.

Caution: TwinScan® instruments contain magnets that may affect your compass. Use care in choosing your mounting location.

2. Start-up Sequence and Normal Operation

The TwinScan® GPH instrument performs a quick self-test each time it is powered up. The self-test verifies adequate power, good ground connections, that the pointers are free, and the LCD display is working. During this test, the pointers will sweep smoothly from zero to full scale and then back to zero. The LCD shows a series of numbers as detailed below (*example values are used so actual numbers may be different*). Switches and configurations are shown on the LCD as: “0123456789AbCdEF”

“8.8.8.8”	Checks LCD segments and backlighting.
“ 1.21”	Software version number.
“F 3”	The red (left) and black (right) switch settings.
“- - 34”	Internal configuration (scale range, units, etc.)
“ ”	Blank
“123.4”	Current total gallons or total liters (normal operation).

After the self-test, the instrument goes into its normal operating mode. The needles indicate fuel flow in gallons (or liters) per hour and the LCD shows the total gallons (or liters) consumed since the last reset.

3. Testing the Totalizer

The TwinScan GPH instrument has a non-volatile memory to track the total fuel consumed and therefore can only be reset by holding the reset switch in the “RESET” position for approximately 15 seconds. You will notice the LCD totalizer blinking during the reset mode—warning you that it is about to reset. After 10-15 seconds, the LCD will blink “E 0.0”. Release the switch to return to normal operation.

4. Illumination

TwinScan® instruments use a dual method of illumination to create a high contrast display making it easy to read at night without affecting your night vision. The pointers are individually lighted so all the port pointers light when the port key switch is energized and all the starboard pointers light when the starboard key switch is energized. “Light piping” directs the light from an incandescent lamp across the dial face instead of bouncing it off the dial face and into your eyes.

5. Caring For Your Instrument

The front lens of your TwinScan® instrument is made of hardened Lexan and is resistant to mild abrasion. Use mild soap and water to clean. Never wipe with a dry cloth. This can scratch the lens and builds up static electricity attracting dust and dirt. Avoid solvents such as acetone, benzene, and lacquer thinner as they attack the surface of the lens. Most window and kitchen cleaners contain at least one of these solvents plus mild abrasives and should be avoided. Applying automobile or furniture wax covers minor scratches on the lens and helps prevent further scratching.

TwinScan 3” Instrument – Tachometer & GPH Gas – NMEA 0183 Input (LCD)

COMBINATION ONLY

This unit conforms to NMEA 183, Version 1.5 and 2.0 interface standards, and requires a message that includes “VTG”, “RMC” or “RMA”. Check your owner’s manual to verify your GPS / LORAN-C includes this information. To insure an easy trouble free installation, read all instructions before starting.

WIRING

1. Refer to the electrical wiring section of the GPS / LORAN-C Owner’s Manual for the proper procedure to connect your GPS / LORAN-C to NMEA 183 devices. Use shielded wire between instruments and ground the shield ONLY at the GPS / LORAN-C (sender end), not at the FloScan instrument end (receiver end). The shield is not to be used as a ground path.
2. Connect the WHITE/ORANGE wire to the NMEA (+) (BNC center terminal) terminal coming from your GPS / LORAN-C instrument.
3. Connect the GREEN/BLACK wire to the NMEA (-) (BNC shield) terminal coming from your GPS / LORAN-C instrument.
4. Connect the BLUE wire to the WHITE/RED wire from the TwinScan GPH meter and to one terminal of a single pole, single throw switch. Connect the other terminal to the BLACK wire (system ground).

CALIBRATION

1. See your GPS / LORAN-C owner’s manual and set output for NMEA 0183 version 1.5 or 2.0 at 4800 bits/sec. (standard). Speed is always sent on the NMEA string as speed over ground in knots no matter what units your GPS / LORAN-C displays.
2. Fuel flow rate calibration is automatically done when the totalizer is calibrated. To calibrate, see the Totalizer calibration instruction page.

FUEL ECONOMY/SYNCH OPERATION

The blue wire must be connected to an operating TwinScan fuel flow meter to show fuel economy, otherwise the instrument shows the synchronizer regardless of this switch position.

1. With the MPG/SYNCH switch in the ON position (BLUE wire closed, grounded), your instrument displays the engine synchronizer. In the OFF (open) position, the instrument shows fuel economy in nautical miles per gallon or liters per nautical mile and is automatically selected by the TwinScan GPH/LPH instrument. You must have valid NMEA 0183 version 1.5 or 2.0 speed data to display fuel economy; otherwise you receive an error code:

ERROR CODES

Display	Reason	Cause
“ OFF ”	No signal activity present on NMEA 0183 terminals for four seconds.	GPS / LORAN-C OFF NMEA OUTPUT not selected Leads not connected (+) & (-) leads reversed
“- . . . -”	Receiving NMEA 0183 Version 1.5 or 2.0 message, but speed message is invalid.	GPS satellite reception is poor GPS / LORAN-C in startup mode
“- Lo -”	(MPG mode) Speed valid but flow rate less than 0.25 GPH.	Flow rate too low—engine stopped
“- hi -”	(LPM mode) Speed valid but less than 0.2 KM.	Speed too low—boat stopped
“Err1”	Some pulsing signal present but no NMEA 0183 message received in last four seconds.	Leads connected to wrong source GPS / LORAN-C set to NMEA 0180 or 0182 (+) & (-) leads reversed.
“Err2”	NMEA 0183 message detected, but no “VTG”, “RMC” or “RMA” sentence found.	GPS / LORAN-C incompatible with NMEA 0183, version 1.5 or newer

Note: THIS SHEET IS TO BE USED ONLY WHEN INSTALLING A TWINSCAN GPH METER AND TACHOMETER COMBINED.

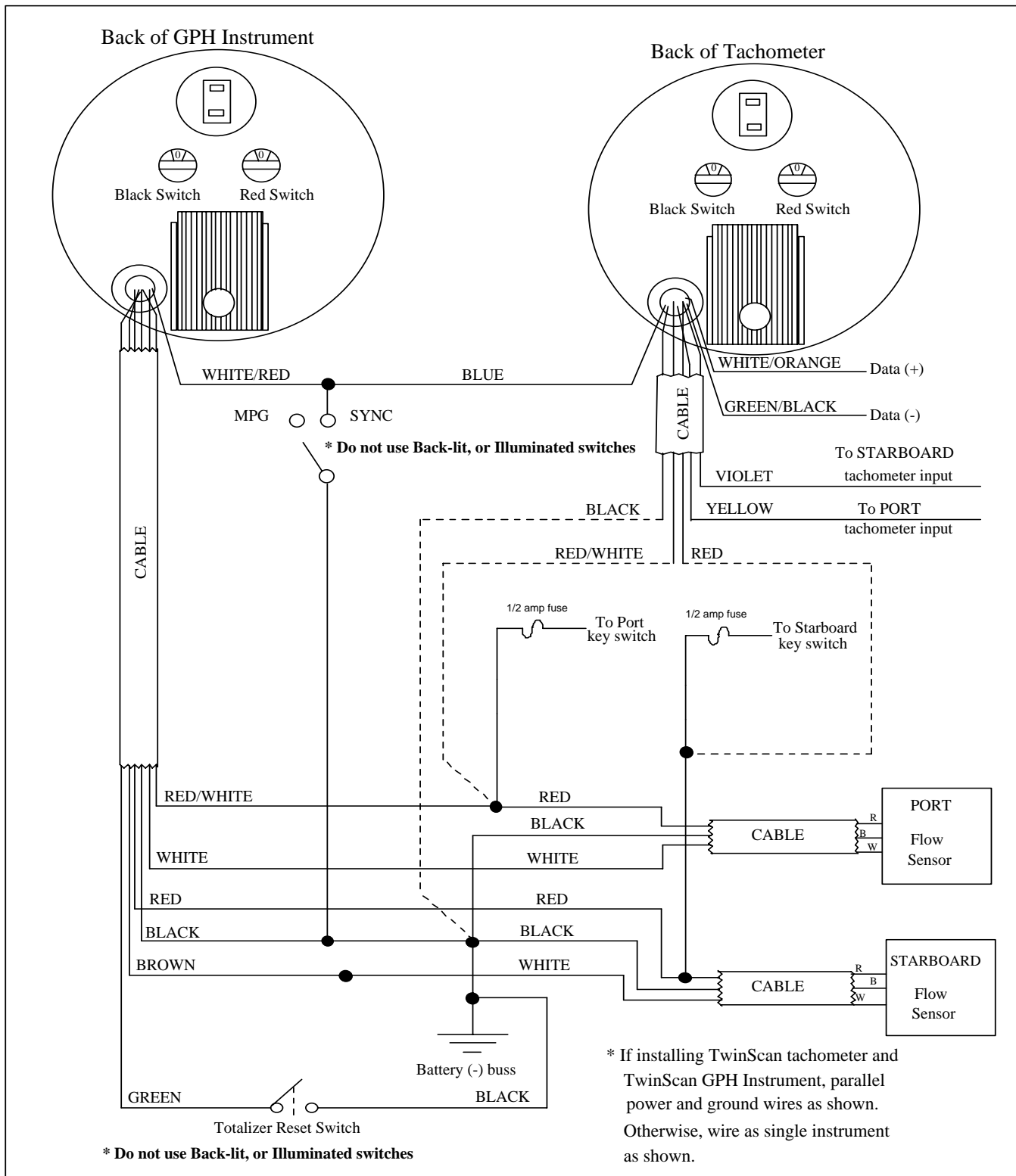

Series 5400(0)/5500(0)/56100/5800(0)/6500(0)/6600(0) AccuTroll & CruiseMaster, All Multi Function Instruments, & TwinScan®

SET UP

Wire & Switches: Use 18 AWG stranded wire on runs under 50'. For runs over 50' use 16 AWG. Shielded wire is recommended for all Diesel systems and suggested for Inboard & I/O gasoline systems. Always, "Ground" the wire shield or shield drain wires in the engine room by connecting them to the bonding system or engine block. The double wiring harness for twin engine Pulse/NMEA Diesel installations is included in all, (97/9800(0)) kits. FloScan suggests using J-Boxes, Terminal Blocks, and three conductor cables between diesel sensors and instrument to make wiring easier.

Install Single Pole Single Throw (SPST) switches for Totalizer Reset, Port-Starboard Select, Engine Hours / Synchronizer, and GPH / MPG, (switches are not included with kit). To determine which switch types are required for your system, refer to the table below. All instruments except TwinScan Tachometers require a totalizer reset switch.

SYSTEM	TOTALIZER RESET	PORT/STBD Twin Engine Systems	HOURS/ SYNCH	GPH/ MPG	MPG/ SYNCH
5400(0)	SPST or Momentary <u>OFF</u>	SPST	NA	NA	NA
5500(0)/56100	SPST or Momentary <u>OFF</u>	SPST	NA	NA	NA
5800(0)	SPST or Momentary <u>OFF</u>	NA	NA	NA	NA
6500(0)/6600(0)	SPST or Momentary <u>OFF</u>	NA	NA	NA	NA
65/6600(0) Cummins PT	SPST or Momentary <u>OFF</u>	SPST	NA	NA	NA
7000/8000(0) Gasoline MFI	SPST or Momentary ON	SPST	SPST	NA	NA
71/8A00(0) MFI - Gasoline EFI	SPST or Momentary ON	NA	NA	NA	NA
75/7600(0) Diesel MFI	SPST or Momentary ON	NA	NA	NA	NA
9000 Gasoline MFI	SPST or Momentary ON	SPST	SPST	SPST	NA
9A00(0) MFI - Gasoline EFI	SPST or Momentary ON	NA	NA	SPST	NA
95/96/97/9800(0)	SPST or Momentary ON	NA	NA	SPST	NA
TwinScan GPH Meter	SPST or Momentary ON	NA	NA	NA	NA
TwinScan Tachometer	NA	NA	NA	NA	NA
TwinScan GPH & Tachometer	SPST or Momentary ON	NA	NA	NA	SPST

NA = Not Applicable

Grounding: Each Black sensor wire must be connected directly to the Black, "Instrument Ground" wire. Use a single wire to connect the Black wire junction to the battery's negative terminal, or a ground buss.

Power: FloScan Instruments & sensors operate on 9 to 12 VDC. Voltages exceeding 16 VDC will damage equipment. 24 & 32 VDC systems must be reduced to 12 VDC. Two different types of voltage reducers are available through FloScan.

WIRE CONNECTIONS

Installation: Connect wires one at a time and install heat shrink tubing before proceeding to the next wire, (refer to diagram). Connect ground wires first, (BLACK instrument ground wire to the BLACK sensor wires). Connect this junction to the battery's negative terminal or the ground buss. Connect all other wires leaving the Red power wires for last to prevent short circuits during installation.

Splicing: Splice or join individual wires per the diagram. Slide heat shrink tubing over the splices to prevent shorts. Do not seal splices until the installation is finished and has been tested.

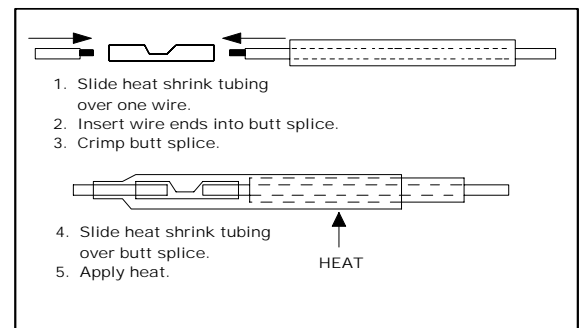

An adequate number of crimp-on connectors and heat-shrink tubing are included with system. The heat-shrink is a special type that will bond to wire insulation and make a watertight connection. See diagram for proper tubing application. Crimp-on connectors are sized for 18 or 20 gauge stranded wire.

Tachometer Wiring Information applies only to MFI & TwinScan Instrument Tachometers

Tachometer signal wires on MFI & TwinScan Tachometers should be shielded.

For proper tachometer operation on gasoline EFI engines, (especially outboards) the engine Ground wire must be physically connected to the MFI or TwinScan instrument ground wire.

Note: FloScan recommends using dedicated 18 AWG shielded cable for tachometer signal wire connections. Always, "Ground" wire shields or the shield drain wire in the engine room by connecting to the bonding system or engine block.

MULTI FUNCTION & TWINSCAN INSTRUMENT TACHOMETERS for CARBURETOR & CLOSED LOOP EFI GASOLINE ENGINES POINTS or STANDARD ELECTRONIC IGNITIONS

Inboard, & I/O Engines: Connect the YELLOW wire from pin # 8 to the distributor coil's negative terminal. On twin engine systems the Yellow wire from pin # 8 connects to the port engine, the VIOLET wire from pin # 16 to starboard.

Outboard Engines: Outboard tachometers are connected to either the engine alternator or tachometer signal wire. Connect the YELLOW wire from pin # 8 to the engine alternator or tachometer signal wire. On twin engine systems the Yellow wire from pin # 8 connects to the port engine, the VIOLET wire from pin # 16 to starboard.

MULTI FUNCTION & TWINSCAN INSTRUMENT TACHOMETERS for CLOSED LOOP EFI GASOLINE ENGINES with CPU IGNITION SYSTEMS

Inboard, I/O, & Outboard Engines: Connect the YELLOW wire from pin # 8 to the engines' tachometer signal wire. On twin engine systems the Yellow wire from pin # 8 connects to the port engine, the VIOLET wire from pin # 16 to starboard.

Outboard Engines: Connect the YELLOW wire from pin # 8 to the engines' tachometer signal wire. On twin engine systems the Yellow wire from pin # 8 connects to the port engine, the VIOLET wire from pin # 16 to starboard.

MULTI FUNCTION INSTRUMENT TACHOMETERS for OPEN RETURN EFI GASOLINE ENGINES with CPU IGNITION SYSTEMS

Inboard & I/O Engines: Connect the YELLOW wire, pin # 8 to the engines' tachometer signal wire.

MULTI FUNCTION INSTRUMENT TACHOMETERS - DIESEL ENGINES

- Keep existing tachometer: Connect the YELLOW and VIOLET wires to the existing tachometer signal wires. If one lead is grounded at the pickup or alternator, connect the YELLOW wire to the tachometer signal wire. Connect the VIOLET wire to a ground buss.
- Replace existing tachometer: Connect the YELLOW and VIOLET wires to the existing magnetic pickup or signal generator. If one lead is grounded at the pickup or alternator, connect the YELLOW wire to the existing signal wire terminal at the tachometer and connect the VIOLET wire to a ground buss.
- Install as a new tachometer. On engine alternator installations, connect the YELLOW wire to the tachometer output terminal (usually marked "tach" or "sig") and connect the VIOLET wire to a ground buss. For mechanically driven A-C signal generators and magnetic pickups, connect the YELLOW wire to one terminal and the VIOLET wire to the other.

TWINSCAN INSTRUMENT TACHOMETERS – DIESEL ENGINES

- Connect the YELLOW wire to one terminal the Port tachometer sender, (AC signal generator, Magnetic pickup, or the engines' alternators tach or sig terminal). Connect the VIOLET wire to the Starboard sender. The tachometer senders' second terminal must be grounded.

FINAL ACTIONS

Check Electrical Installation: Test all connections. Support and secure all dangling wires. Start engine and calibrate system.

Mechanical Installation

Series 5400(0)/ 5500(0)/ 56100/ 7000(0)/8000(0)/ 9000(0), Single Sensor EFI 8A00(0)/9A00(0) and TwinScan® GPH Instruments for Gasoline Inboard/ I/O/ and Outboard Engines

FLOW SENSOR INSTALLATION

Flow Sensors must be placed in a horizontal section of fuel line at a low point in the fuel system. Fuel should travel, “Up-hill” when exiting the sensor. Its outlet should be at least 1 or 2 inches lower than the fuel pump inlet, priming bulb or pulsation damper, (if used). Pulsation Dampers and Priming Bulbs must also be mounted horizontally. Installing sensor(s) 12” upstream of the fuel pump, priming bulb or pulsation damper improves system accuracy. Install sensors in a protected location, away from water spray.

Model 20A, 20B, 231, & 233C gasoline sensors must be installed downstream of a fuel filter or water separator. On vessels not equipped with off engine filters, we suggest installing a Flow Ezy model ILA-02 filter with 238 micron screen directly to the 20A, 20B or 231 Low-Flow Sensors’ inlet. Use model 4ILA-04 with 595 micron screens with High Flow 233C Sensors’.

Flow Ezy can be reached at (800) 237-1165.

Caution: NEVER install sensor(s) downstream of an engine mounted fuel filter. NEVER use Teflon Tape when installing sensors. Teflon Tape can jam a sensor’s rotor. Instead, always use a fuel proof pipe thread sealant.

For proper system operation, Carburetor Inboard & I/O Engines having diaphragm fuel pumps require Gasoline Pulsation Dampers. FloScan Systems are not shipped with Pulsation Dampers’ as carburetor Inboard and I/O engines are no longer in production. If you have a Carburetor Inboard or I/O engine, Pulsation Dampers can be purchased factory direct. Standard Flow Dampers’ are \$30.00 each. The standard Flow Damper can be ordered under Part Number 150-004-00 online at www.floscan.com in the Accessories section.

E-mail: sales@floscan.com, or service@floscan.com.

The following engine types DO NOT require Pulsation Dampers:

- Outboard Gasoline Engines Including Ficht, Optimax, 2 & 4-Cycle.
- Most Closed Loop EFI Gasoline Inboard, and I/O Engines.

- Sensors are marked with orientation and fuel flow arrows. They must be installed with these arrows pointing in the right direction.

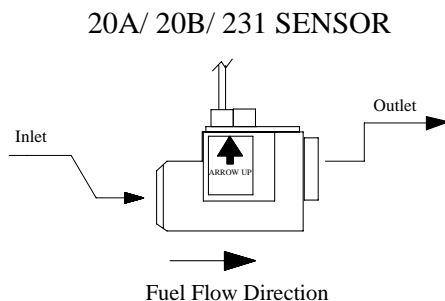

Standard-Flow Pulsation Damper

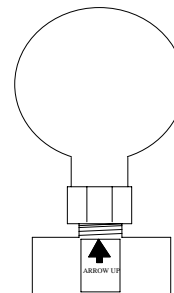

High-Flow Pulsation Damper

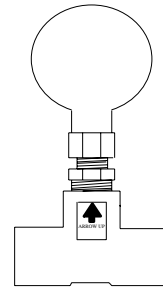
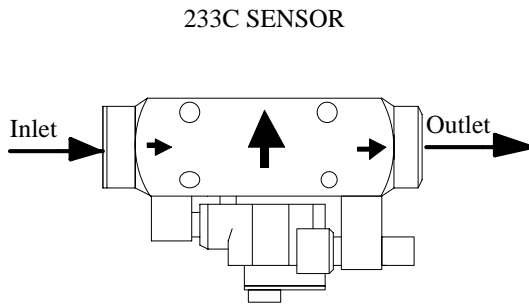

- Install sensor(s) with orientation arrows pointing UP ↑. Fuel must enter through the port marked IN or with an inward pointing → fuel flow arrow, and exit through the port marked OUT or with an outward pointing → arrow.
- The sensor must be installed horizontally at a low point in the fuel system. When fuel exits the sensor it must travel up-hill slightly. One or two inches of vertical rise is adequate, more is ok.
- The sensor must be installed downstream of, and protected by a screen, filter, or water separator. Sensors are tolerant of fine debris. A coarse screen, (up to 800 microns) or water separator is all that is required.
- It is recommended that the sensor be installed between the fuel filter and fuel pump inlet. There should be at least twelve inches of fuel hose, (more is ok) between the sensor and fuel pump inlet.
- If required, the pulsation damper must be installed horizontally, with its orientation arrow pointing up, (refer to fuel flow schematics below).
- **Minimize the number of 90° elbows and pipe fittings.** Excessive use may create a high vacuum, fuel restricting pressure drop across the fuel system. Whenever possible, use a large radius hose bend instead of elbows. Refer to the engine owner's manual for maximum fuel pump vacuum. A vacuum gauge can be used to confirm that the system is within limits.
- If swivel fittings are used, (JIC or SAE) their mating surfaces should be sealed with AP 50 Copper Conical Sealing Washers or Flare-tite Fitting Seals. Seals and sealing washers can be purchased through Fittings Inc. in Seattle, WA (206) 767-4670, 1-800-552-0632, or a local hydraulic supply house.

CAUTION, DO NOT OVER TIGHTEN FLOW SENSOR FITTINGS. Over-tightening may crack the sensor's body. Cracks cause leaks and fuel leaks sometimes cause catastrophic explosions and fire. Assemble fittings with a Lubricating, Fuel Proof, Non or Semi Hardening pipe thread sealant, designed for aluminum and stainless steel threads, (Loctite 567 or equivalent).

DO NOT USE TEFLON TAPE.

INSTRUMENT INSTALLATION

- Before cutting holes in your Instrument Panel, verify that the instrument will be installed approximately 12" away from the compass, and in a shaded location out of direct sunlight. Mounting it within 12" of a compass may interfere with compass operation. Direct sunlight may cause the LCD display to temporarily turn black due to heat.

Instrument Series	Cutout Size	Instrument Depth
5400(0), 5500(0)	3 1/16"	3" – Console Panel Thickness
7000(0), 8000(0), 9000(0), TwinScan®	3 3/8"	2 1/2" – Console Panel Thickness

Table 1

Standard-Flow Gasoline System Schematics

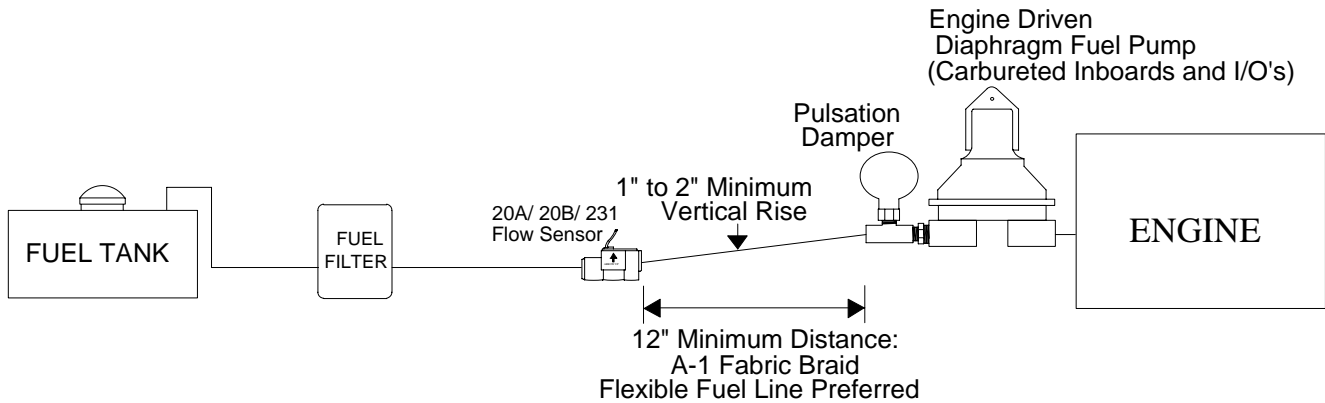
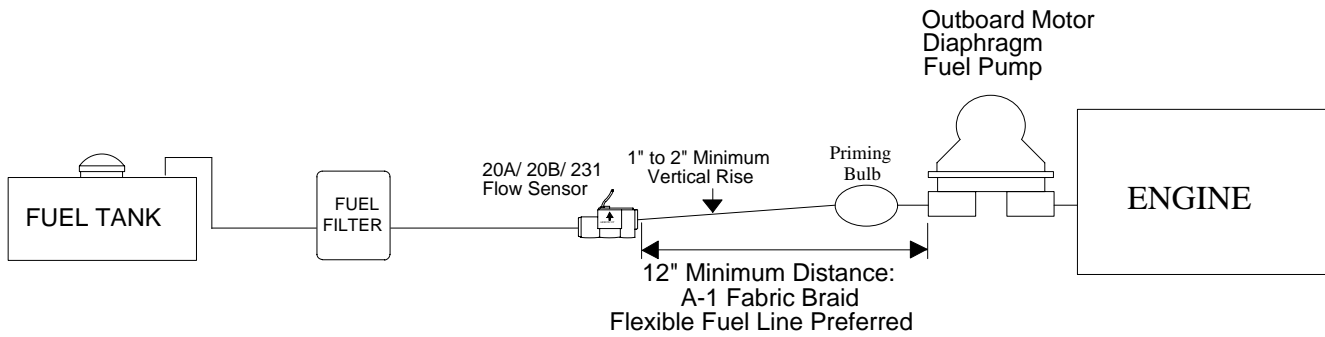
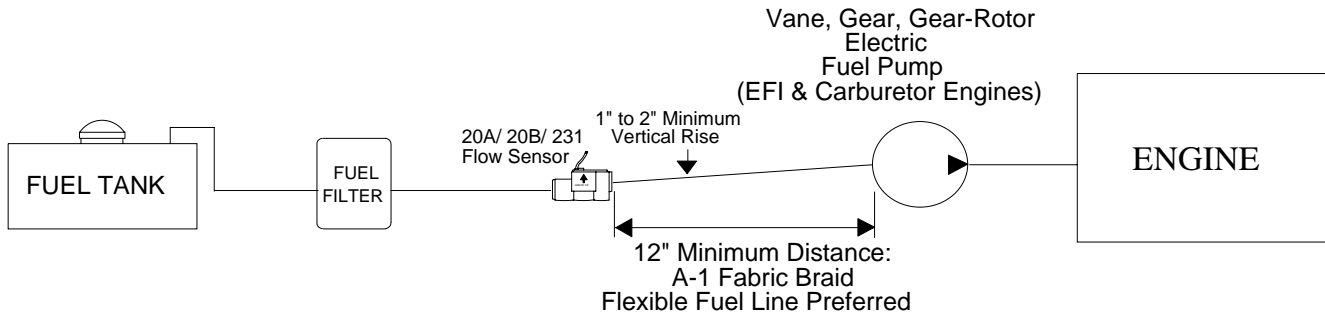

High-Flow Gasoline Fuel Flow Schematics

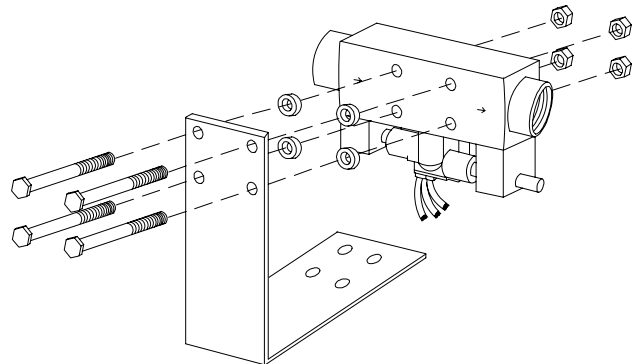
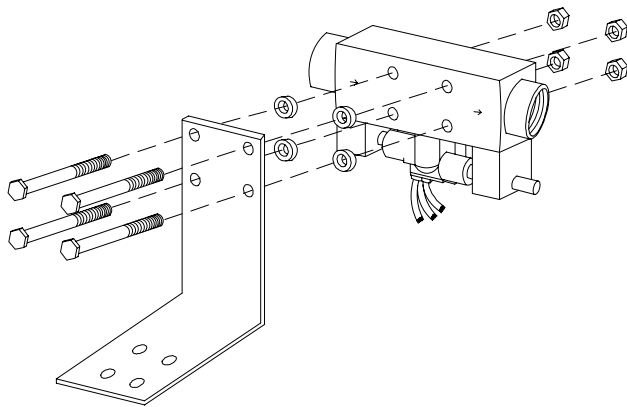
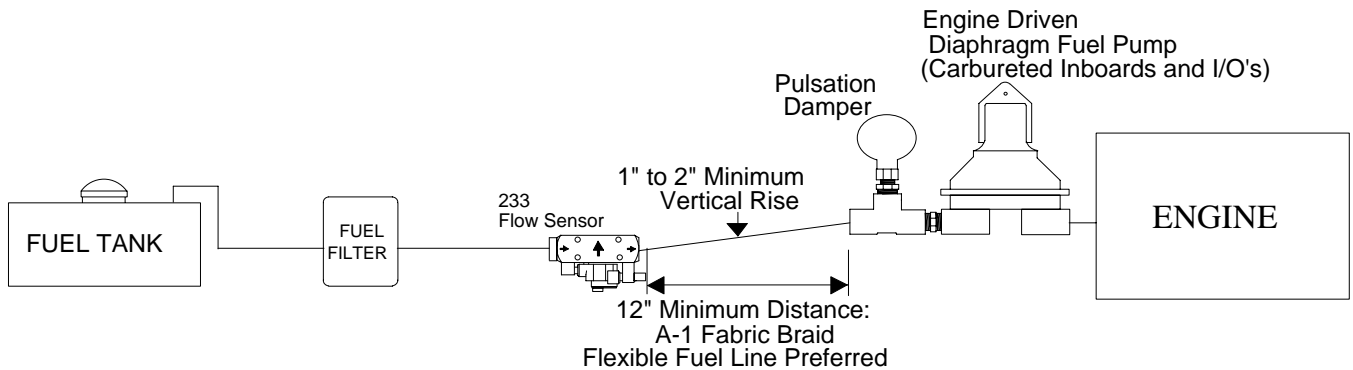
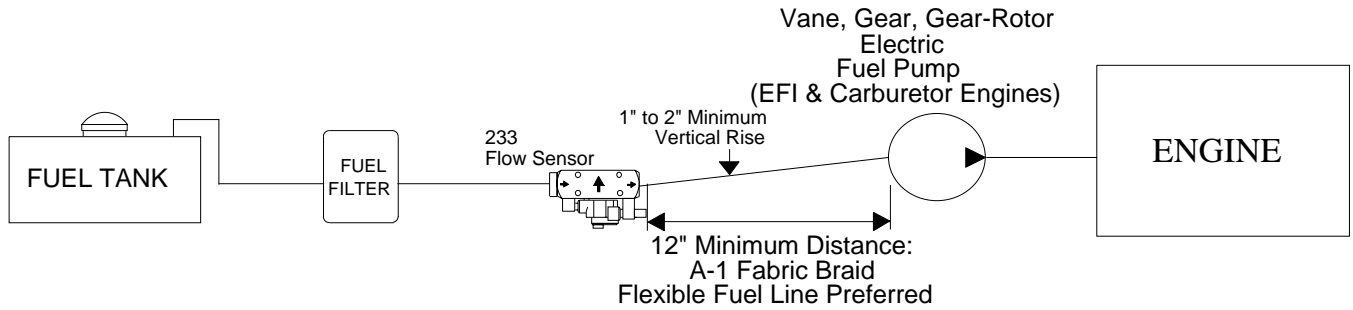

High-Flow Sensor Bracket Assembly

TwinScan® Gas 3” GPH Instrument Only

To ensure years of trouble free operation of your new TwinScan® Instrument please read all of these instructions carefully before beginning your installation.

CAUTION: To avoid electrical shorts and possible fire, turn **OFF** the power to the instrument panel until installation is complete.

Please Note: The pointer is accurate only when gauge is energized. The pointer may stop at any position when power is **OFF** and is not indicative of a faulty gauge.

This instrument fits in a standard 3 3/8” tachometer hole. The analog needles show the *PORT* and *STARBOARD* fuel flow rates of each engine and the totalizer shows the total consumption of both engines. Fuel consumption is stored in non-volatile RAM and does not require power to retain its memory. Resetting the totalizer is done with an external switch (not supplied). An excellent choice is a momentary on (normally open) switch. You can also use a single throw, single pole (SPST) switch.

Wiring

Use No. 18 AWG mufti-strand wire, the included butt splices and self-sealing heat shrink to make all connections. **Alternate installation:** Use insulated ring tongue connectors and a terminal strip.

Important: Protect wires from damage caused by sharp edges, moving and hot engine parts. Cable tie and support all wire runs for safety.

Wire Color	Function
RED/WHITE	PORT Instrument & flow sensor +12 VDC Power
RED	STARBOARD Instrument & flow sensor+12 VDC Power
BLACK	Battery Ground (Instrument & flow sensor ground)
WHITE	PORT Flow Sensor Input
BROWN	STARBOARD Flow Sensor Input
GREEN	Totalizer Reset Switch
WHITE/RED	Pulse Output to Tachometer/MPG Switch if Installed

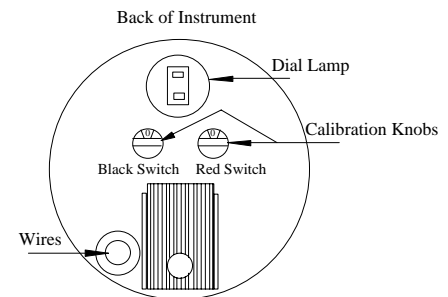

1. Connect the *RED/WHITE* wire to the “power on” side of the *PORT* ignition switch.
2. Connect the *RED* wire to the “power on” side of the *STARBOARD* ignition switch. In multiple gauge installations, join all the *RED/WHITE* wires together and run a single wire to the keyed terminal of the *PORT* ignition switch. Do the same for the *RED* wires on the *STARBOARD* side.
3. Connect the *BLACK* wire of the gauge to the *BLACK* wire(s) at the flow sensor(s). Run a *BLACK* wire to the negative battery bus from this point. This instrument requires a single point ground system. Connecting the gauge to a ground at the instrument panel and the flow sensor(s) to a different ground can introduce noise and affect the accuracy of the instrument.
4. Connect the *WHITE* wire of the instrument to the *WHITE* wire of the *PORT* flow sensor.
5. Connect the *BROWN* wire of the instrument to the *WHITE* wire of the *STARBOARD* flow sensor.
6. Connect the *GREEN* wire to one of the terminals of a single pole, single throw (SPST) or momentary on (normally open) switch. Run a *BLACK* wire from the other terminal of the switch to the Instrument *BLACK* wire (ground.) *Totalizer reset switch OPEN* - Normal operation , *Totalizer reset switch CLOSED* - Reset mode.

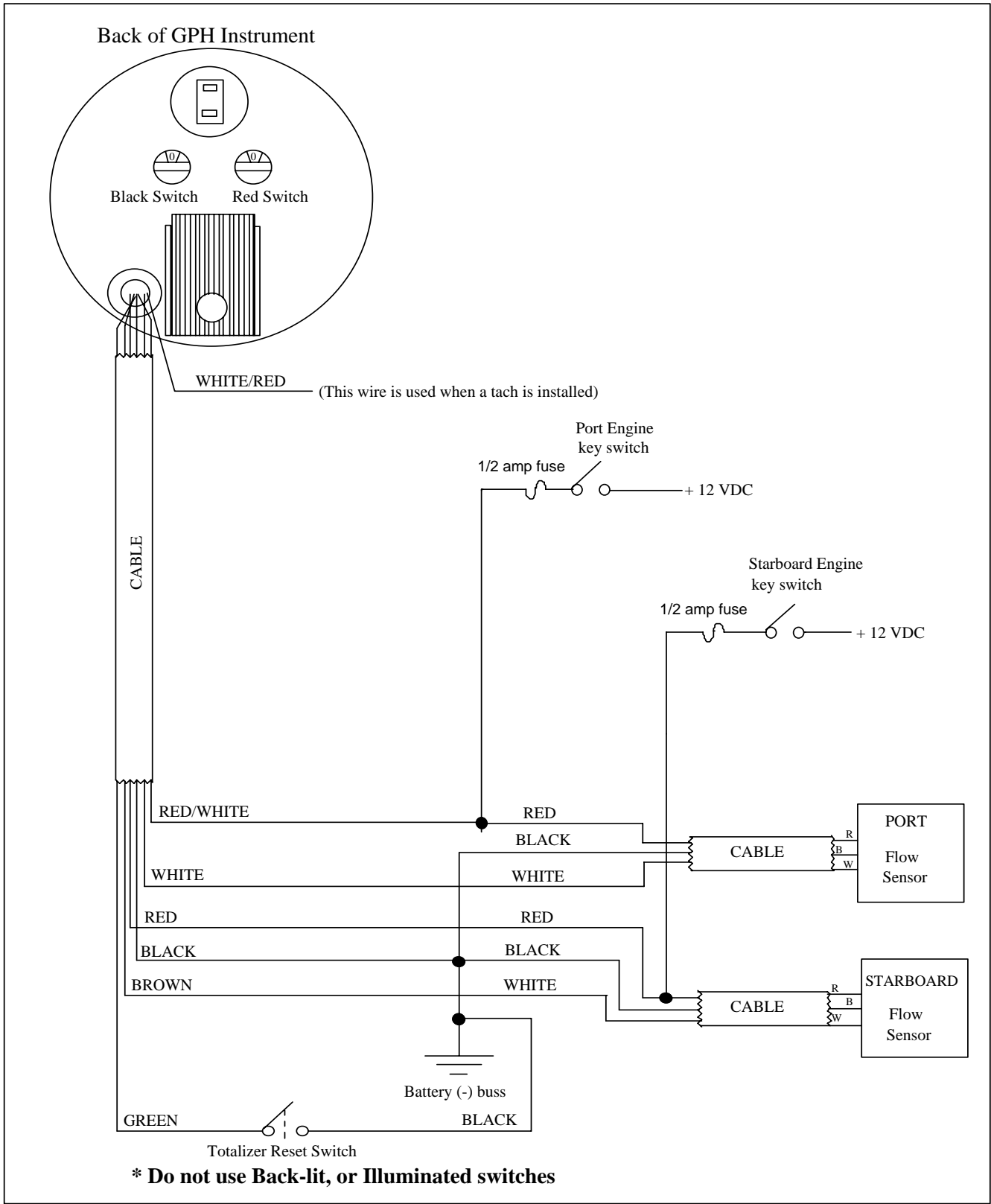

**TwinScan® 3” GPH Instrument
Gasoline and Diesel Engines**

*To ensure years of trouble free operation of your new GPH Meter,
please read all of these instructions carefully before beginning your installation.*

Calibration and flow sensor selection of your TwinScan® 3” GPH Instrument is done with the sixteen position rotary switches on the back of the instrument. The RED switch is used for sensor type and pointer damping selection; the BLACK switch is used to calibrate your instrument. It is critical that you set the sensor selection switch correctly. Before re-calibrating your instrument, note the current position of the switch and check the calibration table for the correct flow sensor selection. Changing the totalizer calibration also changes the analog needle calibration.

Re-calibration is required only if you find your totalizer reading to be more than 2% different from the actual fuel put into the tank. Various things such as the attitude of the boat in the water, the amount of the fill up, and how full the tank is filled affect accuracy. The larger the amount of fuel you base calibration on, the more accurate your system will be.

To check the calibration:

1. Fill the tank(s) and reset the totalizer to zero.
2. Operate the boat in a normal manner until you would ordinarily refuel.
3. Fill the tank(s) as close to the same level as possible. Check the amount of fuel the tank actually took as well as the amount the totalizer shows you used. In most cases, these two amounts are within 2% of each other and no additional calibration is required.
4. To change the calibration, rotate the BLACK switch on the back of the instrument until the totalizer reads as close to your actual fill up as possible. If your reading is off by more than you can calibrate, go to the troubleshooting guide.

BLACK Switch	Effect to Totalizer
0	No Change
1	+2%
2	+4%
3	+6%
4	+8%
5	+10%
6	-20%
7	-18%
8	-16%
9	-14%
A	-12%
B	-10%
C	-8%
D	-6%
E	-4%
F	-2%

RED Switch	Sensor	Results
0	20B	Light meter damping
1	20B	Heavy meter damping
2	20B	Light meter damping
3	20B	Light meter damping
4	231	Light meter damping
5	231	Heavy meter damping
6	231	Light meter damping
7	231	Light meter damping
8	233C	Light meter damping
9	233C	Heavy meter damping
A	233C	Light meter damping
B	233C	Light meter damping
C	w/diesel*	Light meter damping
D	w/diesel*	Heavy meter damping
E	w/diesel*	Light meter damping
F	w/diesel*	Light meter damping

*TwinScan + MFI combination

TwinScan® 3” Instrument - Gallons Per Hour (LCD)

BEFORE CALLING FOR ASSISTANCE, COMPLETE THESE TROUBLESHOOTING CHECKS AND RECORD YOUR FINDINGS. TECHNICAL SUPPORT REQUIRES THIS INFORMATION BEFORE A RETURN AUTHORIZATION WILL BE ISSUED. IT TAKES ABOUT 20 MINUTES AND IS VERY IMPORTANT IN ANALYZING SYSTEM PROBLEMS.

Before starting, record instrument model number and switch settings.

MODEL # _____ SERIAL # _____

RED SWITCH POSITION _____ BLACK SWITCH POSITION _____

Perform the Instrument Diagnostic & Duty Cycle Tests outlined in Sections I & II First. Record your findings.

I. INSTRUMENT DIAGNOSTIC SELF-TEST

- Secure power to the Red, and Red/White wires, (Turn both key switches OFF).
- Turn power on, (Either to one or both switches). At start-up, the instrument automatically performs a, “Self-test”.
- Verify that the pointer’s back-lighting glows Red, and that the LCD back-light is glowing Green.
- Observe that the pointers smoothly sweep to near full scale, (Slightly above or below) then smoothly drop back to zero.

The LCD display shows the following numbers and letters in sequence. These are examples, actual readings may vary. Switch settings and configurations are shown on the LCD as, “0123456789AbCdEF”.

8.8.8.8	LCD segment and back-lighting check.
1.21	Software version number.
F 3	Red, (Port) and Black (Starboard) switch settings.
- - 34	Internal configuration (scale range, units, etc.)
	Blank
123.4	Current total gallons or total liters, (Indicates normal operation).

- Record the software version _____ and switch settings _____ . FloScan Technical Support will ask for these.

The self-test verifies adequate power, a good ground, that the pointers move, and the LCD display is working.

If the self-test fails, the LCD shows, “PO” plus a two-digit number code. The pointers also show the error number as a, “Blink Code”. Sitting near center scale the pointers will twitch upwards, showing a numeric value. For Po23 the pointers twitch twice, pause for a moment, and then twitch three times. After a long wait the twitching resumes. This continues until power is secured. If the self-test fails, verify that supply voltage is at least 10 VDC. If voltage drops below 10V, the self-test may fail.

II. DUTY CYCLE TEST

- Start both engines and run at idle.
- Close and open the RESET switch twice within 0.6 seconds—like double-clicking a computer mouse.
- The LCD will show **dcy** when it’s in duty cycle check mode.
- With the display showing **dcy** the pointers should remain steady and in the middle third of their scales.
- At very low flow rates, the pointers track the on/off signal from each sensor and will wiggle.
- Increase engine rpm until the pointers are steady.
- Steady readings with occasional, “Hick-ups” may indicate air or vapor bubbles passing through the sender.
- “Double-click” the RESET switch to return to the normal fuel flow display mode.

FAULT	PROBABLE CAUSE	SEE SECTION:
Blank LCD Display	Wiring	Section III
No back-lighting	Wiring/bulb failure	Section
Low Totalizer Reading, over 10%	Calibration Sensor orientation/failure	Calibration sheet Section IV, Install. sheets
High Totalizer Reading, over 10%	Incorrect/defective sensor Incorrect switch settings Suction leak	Section IV Calibration sheet Section VII
Fluctuating GPH Readings	Suction leak Low RPM operation	Section VII Section X
No GPH or Totalizer Reading	Wiring/Instrument failure Sensor orientation/failure	Section I, II, III, and V Section IV, Install. sheet
Wire Harness Continuity Test		Section V

III. SUPPLY VOLTAGE and GROUND TEST

- Measure voltage between the Starboard RED power wire, and the BLACK Instrument ground wire. _____ VDC
- Measure voltage between the Port RED/WHITE power wire, and the BLACK Instrument ground wire. _____ VDC

These readings should be approximately 12 - 14 VDC, but not lower than 10 VDC.

- If 12 VDC is not present, measure between the RED, or RED/WHITE power wire and a known good ground in the instrument panel. If you measure 12 to 14 VDC, there may be an instrument ground problem. _____ VDC
- If 12 to 14 VDC is not present check wiring, switches, fuse, and the 12 VDC power source.

IV. SENSOR(S) TEST

1. With your voltmeter set to a DC scale greater than 14 volts, measure between the RED (+12VDC) and BLACK (Instrument ground) wires. With engine idling, measure and record the voltage reading. _____ VDC
2. Move the voltmeters' negative lead to the WHITE (Signal) wire. With engine idling, measure and record the voltage reading. Readings between 4 and 10 VDC usually indicate a good sensor. _____ VDC
3. Stop the engine while observing the voltmeter. Readings should fluctuate between a high of 9 to 12 VDC, and a low of 0 to 4 VDC as the sensors' turbine slows to a stop. _____ VDC

NOTE: This may not be seen on a digital voltmeter.

4. Move the voltmeters' negative lead to the BROWN (Signal) wire. With engine idling, measure and record the voltage reading. Readings between 4 and 10 VDC usually indicate a good sensor. _____ VDC
5. Stop the engine and observe the voltmeter. Voltage readings should fluctuate between a high of 9 to 12 VDC, and a low of 0 to 4 VDC as the Sensors' turbine slows to a stop.

NOTE: This may not be seen with a digital voltmeter.

6. The Sensor may be defective if voltage readings in steps 3 & 5 remain constant while the engine is stopping.
7. On twin engine systems, try swapping the Brown & White signal wires. Observe the Instrument and see if the problem shifts sides, or remains on the same side.

- The Sensor(s) may be defective if voltage readings in steps 3 & 5 remain constant.
- If signal voltages in steps 3 & 5 are ok, go to the backside of the Instrument. With engine(s) running, measure and record voltage readings across the Red/White & White, (Port Sensor) and Red & Brown, (Starboard Sensor) signal wires. These voltage readings should match the Sensor' readings. This verifies that the Sensors' signal output is reaching the Instrument. If not there is a wiring problem.

V. CONTINUITY TEST

1. Continuity testing requires access to the back of the Instrument and an Ohmmeter. It verifies that wires are not broken, shorted to ground, another wire, or to power. Before starting, secure all power. You will be testing the WHITE, BROWN, and BLACK wires.

2. Disconnect the WHITE and BLACK wire harness conductors from the WHITE and BLACK Port Sensor & Instrument wires. Connect a jumper from the WHITE wiring harness conductor to a known good ground. At the Instrument, connect an Ohmmeter lead to its' WHITE wiring harness conductor. Connect the other Ohmmeter Lead to a known, good ground. The Ohmmeter should read approximately 0.1 to 3 Ω . _____ (Ohm Reading)

Connect a jumper from the Black wiring harness conductor to a known good ground. At the Instrument connect an Ohmmeter lead to its' Black wiring harness conductor. Connect the other Ohmmeter Lead to a known, good ground. The Ohmmeter should read approximately 0.1 to 3 Ω . _____ (Ohm Reading)

3. Disconnect the Brown and BLACK wire harness conductors from the WHITE and BLACK Starboard Sensor & Instrument wires. Connect a jumper from the BROWN wiring harness conductor to a known good ground. At the Instrument, connect an Ohmmeter lead to its' BROWN wiring harness conductor. Connect the other Ohmmeter Lead to a known, good ground. The Ohmmeter should read approximately 0.1 to 3 Ω . _____ (Ohm Reading)

Connect a jumper from the Black wiring harness conductor to a known good ground. At the Instrument connect an Ohmmeter lead to its' Black wiring harness conductor. Connect the other Ohmmeter Lead to a known, good ground. The Ohmmeter should read approximately 0.1 to 3 Ω . _____ (Ohm Reading)

VI. PULSATION PROBLEMS

A stiff anti-siphon valve, sticking carburetor float or miss-plumbed Pulsation Damper(s) can cause fluctuating GPH readings. These are most pronounced at low Rpm's and tend to disappear around mid throttle. They are annoying, but won't affect totalizer accuracy. To eliminate, repair or replace any defective parts, or re-plumb dampers according to the Fuel Flow Schematic Instructions.

VII. FINDING FUEL SYSTEM VACUUM LEAKS

Fluctuating GPH and High Totalizer Readings are usually caused by a small vacuum leak between the fuel tank and fuel pump inlet. Fluctuations tend to be between 2 and 4 GPH. These vacuum leaks also affect totalizer accuracy, causing it to read 15 to 100% high. Larger leaks produce greater fluctuations and higher readings. They generally do not affect engine performance.

Finding suction leaks can be time-consuming. When approached properly, they can usually be found and repaired quickly. Two common places for suction leaks to occur are at the primary fuel filter - water separator, and/or a loose valve stem packing nut.

Remove the filter housing and coat all o-rings, gaskets and sealing surfaces with a medium to heavy grease, (**Do not use oil**) and reassemble. Grease all valve stem packings and gently tighten gland nuts. Don't over tighten, valve handles should turn freely. Tighten all hose clamps and compression fittings. Don't over tighten. Run the engine for 5 to 10 minutes observing GPH readings. If you've found the problem, fluctuations should be reduced to less than 1/2 GPH.

If the problem persists, temporarily install a clear piece of fuel resistant hose downstream of the forward flow sensor. Run the engine and watch for a stream of small bubbles in the clear hose, or an occasional larger bubble. Sometimes shining a light through the hose makes bubbles easier to see.

Observe the clear hose while shaking the fuel lines. If the bubble stream continually increases or decreases you've found the leak area. Repair or replace as needed. If this occurs one-time, you probably dislodged some trapped air.

If the leak hasn't been found, the last step is to inspect each pipe joint. Thread sealant should be visible around each joint. If not, that joint is suspect and must be resealed. After resealing run the engine for a few minutes to purge any remaining air. There should now be bubble free fuel running through the clear hose. If bubbles are still present a leak was missed. Recheck your work. After all the leaks are stopped, remove the clear hose.

VIII. FUEL FILTERS

A dirty fuel filter, or one that is too fine (1-25 micron) will draw vapor bubbles out of the fuel, causing fluctuations and high readings. Replace it with a new 30-micron or coarser filter.

IX. FLOW SENSOR ORIENTATION

Sensor orientation is critical for proper operation. All Sensors have their inlet and outlet ports clearly marked (**IN / OUT** or **→ →**). This identifies fuel flow direction. The Sensor must be, "Plumbed" correctly for it to operate properly. There is an additional single arrow on the Sensor body. It is crucial that this single arrow points up **↑**.

X. LOW RPM OPERATION

At idle, under a no load condition, it is common for GPH readings to fluctuate slightly.

**This concludes system testing. If problems with your system persist,
contact FloScan Technical Support with testing results.**